

MULTI SPLIT

SERIES



SELECTION

Choose from types of indoor units and outdoor units that can run up to six indoor units each. Create the system that best matches room shapes and number of rooms.

R32 INDOOR UNITS		R32 OUTDOOR UNITS		
Wall-mounted  MSZ-RW25-50  MSZ-LN18-50  MSZ-AY25-50  MSZ-AY15-20  MSZ-EF18-50  MSZ-BT25-35  MSZ-AP60  MSZ-FT25-35  MSZ-HR25-50  MSZ-DR25-35	Floor-standing  MFZ-KT25-50  SFZ-M25-71	2-port up to 2 indoor units  MXZ-2F33VF5  MXZ-2F42VF5  MXZ-2F53VF(H)5	3-port up to 3 indoor units  MXZ-3F54VF5  MXZ-3F68VF5	4-port up to 4 indoor units  MXZ-4F72VF5  MXZ-4F80VF5  MXZ-4F83VF3
	Ceiling-suspended  PCA-M50-60	5-port up to 5 indoor units  MXZ-5F102VF3	6-port up to 6 indoor units  MXZ-6F120VF3	
Cassette  SLZ-M15-50  MLZ-KP25-50  MLZ-KY20	Ceiling-concealed  SEZ-M25-71  PEAD-M35-71	Hyper Heating  MXZ-2F53VFHZ3  MXZ-4F83VFHZ3		
		HA Series  MXZ-2HA40VF3  MXZ-2HA50VF3  MXZ-3HA50VF3		

CHECK SYSTEM COMPATIBILITY

Possible combinations depends on the outdoor unit chosen. Please check the following points.

Check Indoor Units

Refer to the "Indoor Unit Compatibility Table" to check if the indoor units selected can be used with the outdoor unit selected. (Indoor units not listed in the table cannot be used.)

Check Indoor Unit Capacity Combination

Refer to the "Indoor Unit Compatibility Table" to check if the capacity combination of the indoor unit selected is connectable. (Combinations not listed cannot be connected.)

If the desired combination cannot be found, please change either the indoor or outdoor unit to match one of the combinations shown in the tables.

MXZ SERIES

Advancements in the MXZ Series include efficiency and flexibility in system expansion capabilities. The best solution when requiring multi-system air conditioning needs.



R32

2-port

MXZ-2F33VF5
MXZ-2F42VF5
MXZ-2F53VF(H)5



R32

3-port 4-port

MXZ-3F54VF5
MXZ-3F68VF5
MXZ-4F72VF5
MXZ-4F80VF5



R32

4-port 5-port

MXZ-4F83VF3
MXZ-5F102VF3



R32

6-port

MXZ-6F120VF3

EXAMPLE SYSTEM



Units can be Used Even if it is Connected to Only One Indoor Unit (4F83/5F102/6F120)

This unit can be used even if it is connected to only one indoor unit. This offers more flexibility for wide range of application that satisfies various customers' demand.

No Necessity for Refrigerant Charging

Depending on the pipe length and the indoor units that are connected, conventional models have required refrigerant charging, but no R32 MXZ model needs to be charged with additional refrigerant. This eliminates troublesome work at the site of installation, and reduces the amount of additional work for the installer.

Handle Up to 6 Rooms with a Single Outdoor Unit

The MXZ Series for R32 offers a ten-system line-up to choose from, ranging between 3.3 and 12.0kW. All of them are compatible with specific M, S and P series indoor units. A single outdoor unit can handle a wide range of building layouts.

Low Noise Mode

Low Noise Mode offers a two-stage setting: 1. Single click: Only the outdoor unit operates more quietly. 2. Double click: The remote controller beep sound is turned off, the indoor unit's lamp is dimmed, and the outdoor unit operates even more quietly. We recommend using setting 1 during the day and setting 2 at night for optimal comfort.

Low Noise Mode			
Click	Remote controller Beep	Indoor unit Lamp	Outdoor unit noise
	ON	ON	LOW
	OFF	DIM	VERY LOW

Support Functions

Wiring/Piping Correction Function* (3F54/3F68/4F72/4F80/4F83/5F102/6F120)

Simply press a single button to confirm if wiring and piping are properly connected. Wiring errors are corrected automatically when discovered. This eliminates the need to confirm complicated wiring connections when expanding the system. (For details, refer to the outdoor unit installation manual.)

* Function cannot be used when the outdoor temperature is below 0°C. The correction process requires 10–20 minutes to complete and must be conducted with the unit set to the "Cooling" mode.

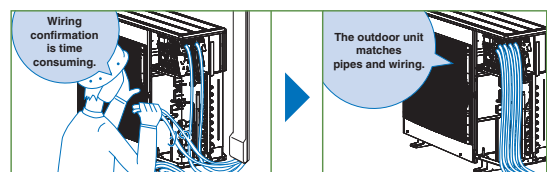

Operation Lock

To accommodate specific use applications, cooling or heating operation can be specified when setting the control board of the outdoor unit. A convenient option when a system needs to be configured for exclusive cooling or heating service. (For details, refer to the outdoor unit installation manual.)



Type (Inverter Multi - Split Heat Pump)			Up to 2 Indoor Units				Up to 3 Indoor Units			Up to 4 Indoor Units		Up to 5 Indoor Units
Indoor Unit			Please refer to*3									
Outdoor Unit			MXZ-2F33VF5	MXZ-2F42VF5	MXZ-2F53VF5	MXZ-2F53VHF5	MXZ-3F54VF5	MXZ-3F68VF5	MXZ-4F72VF5	MXZ-4F80VF5	MXZ-4F83VF3	MXZ-5F102VF3
Refrigerant			R32									
Power Supply			Outdoor power supply									
Source			220 - 230 - 240V / Single / 50Hz									
Outdoor (V/Phase/Hz)												
Cooling	Capacity	Rated	kW	3.3	4.2	5.3	5.4	6.8	7.2	8.0	8.3	10.2
		Min - Max	kW	1.1 - 3.8	1.1 - 4.4	1.1 - 5.6	2.9 - 6.8	2.9 - 8.4	3.7 - 8.8	3.7 - 9.0	3.7 - 9.2	3.9 - 11.0
	Input	Rated	kW	0.85	0.98	1.40	1.32	1.84	1.85	2.25	1.97	2.80
	Design Load		kW	3.3	4.2	5.3	5.4	6.8	7.2	8.0	8.3	10.2
	Annual Electricity Consumption*1		kWh/a	189	169	216	222	301	311	368	342	436
	SEER*3			6.1	8.7	8.6	8.5	7.9	8.1	7.6	8.5	8.2
Energy Efficiency Class*3			A++		A+++		A++			A+++		A++
Heating	Capacity	Rated	kW	4.0	4.5	6.4	7.0	8.6	8.8	9.3	10.5	
		Min - Max	kW	1.0 - 4.1	1.0 - 4.8	1.0 - 7.0	2.6 - 9.0	2.6 - 10.6	3.4 - 10.7	3.4 - 11.0	3.4 - 11.6	4.1 - 14.0
	Input	Rated	kW	0.91	0.88	1.56	1.40	1.91	1.87	2.00	2.28	
	Design Load		kW	2.7	3.5	5.2	6.8	7.0	7.4			
	Declared Capacity	at reference design temperature	kW	2.2	2.7	4.2	5.7	5.6	5.8	5.9		
	Capacity	at bivalent temperature	kW	2.4	2.9	4.8	6.4	6.2	6.2	6.4		
	Capacity	at operation limit temperature	kW	1.6	2.3	2.1	3.2	4.6	4.8	4.9		
	Back Up Heating Capacity		kW	0.5	0.8	1.0	1.1	1.4	1.2	1.5		
	Annual Electricity Consumption*1		kWh/a	944	1065	1089	1583	2321	2389	2087	2205	
	SCOP*3			4.0	4.6	4.5	4.6	4.1	4.7			
Energy Efficiency Class*3			A+		A++		A+			A+++		
Max. Operating Current (Indoor+Outdoor)			A		12.2		18.0			21.4		
Outdoor Unit	Dimensions	H*W*D	mm	550 - 800 (+69) - 285 (+59.5)				710 - 840 - 330 (+66)			796 - 950 - 330	
	Weight		kg	33	37	38	58	59	61			
	Air Volume	Cooling	m³/min	30.8	28.4	32.7	31	35.4	40.3	57	63	
		Heating	m³/min	32.3	33.5	34.7	31	39.6	42.7	44.1	62	75
	Sound Level (SPL)	Cooling	dB(A)	49	44	46	48	50	49	52		
		Heating	dB(A)	50	51	50	53	54	55	51	56	
	Sound Level (PWL)	Cooling	dB(A)	60	59	61	60	63	65	61	65	
Breaker Size		A	15			25			21.4			
Ext. Piping	Port Diameter	Liquid	mm	6.35 x 2			6.35 x 3		6.35 x 4		6.35 x 5	
		Gas	mm	9.52 x 2			9.52 x 3		12.7 x 1+9.52 x 3		12.7 x 1+9.52 x 4	
	Total Piping Length (max)	m	20	30	50	60	70	80				
	Each Indoor Unit Piping Length (max)	m	15	20	25							
	Max. Height	m	10	15 (10) ²	15 (10) ²	15						
Chargeless Length	m	20	30	50	60	70	80					
Guaranteed Operating Range [Outdoor]	Cooling	°C					-10 ~ +46					
	Heating	°C	-15 ~ +24		-20 ~ +24		-15 ~ +24			R32/675 ³		
Refrigerant/GWP			R32/675 ⁴									
Pre-Charged Quantity	Weight	kg	0.8	1.0	2.4							
	CO ₂ equivalent	t	0.54	0.68	1.62							
Max Added Quantity	Weight	kg	0.8	1.0	2.4							
	CO ₂ equivalent	t	0.54	0.68	1.62							

Type (Inverter Multi - Split Heat Pump)			Up to 6 Indoor Units	
Indoor Unit			Please refer to*3	
Outdoor Unit			MXZ-6F120VF3	
Refrigerant			R32	
Power Supply			Outdoor power supply	
Source			220 - 230 - 240V / Single / 50Hz	
Outdoor (V/Phase/Hz)				
Cooling	Capacity	Rated	kW	12.0
		Min - Max	kW	3.5 - 14.0
	Input	Rated	kW	3.60
	Design Load		kW	12.0
	Annual Electricity Consumption*1		kWh/a	612
	SEER*3			6.8
Energy Efficiency Class*3			A++	
Heating	Capacity	Rated	kW	14.0
		Min - Max	kW	3.5 - 16.5
	Input	Rated	kW	3.31
	Design Load		kW	8.1
	Declared Capacity	at reference design temperature	kW	6.9
	Capacity	at bivalent temperature	kW	7.6
	Capacity	at operation limit temperature	kW	5.7
	Back Up Heating Capacity		kW	1.2
	Annual Electricity Consumption*1		kWh/a	2794
	SCOP*3			4.0
Energy Efficiency Class*3			A+	
Max. Operating Current (Indoor+Outdoor)			A	
A			29.8	
Outdoor Unit	Dimensions	H*W*D	mm	1048 - 950 - 330
	Weight		kg	87
	Air Volume	Cooling	m³/min	63
		Heating	m³/min	77
	Sound Level (SPL)	Cooling	dB(A)	55
		Heating	dB(A)	57
	Sound Level (PWL)	Cooling	dB(A)	69
Breaker Size		A	32	
Ext. Piping	Port Diameter	Liquid	mm	6.35 x 6
		Gas	mm	12.7 x 1 + 9.52 x 5
	Total Piping Length (max)	m	80	
	Each Indoor Unit Piping Length (max)	m	25	
	Max. Height	m	15	
Chargeless Length	m	80		
Guaranteed Operating Range [Outdoor]	Cooling	°C	-10 ~ +46	
	Heating	°C	-15 ~ +24	
Refrigerant/GWP			R32/675 ⁴	
Pre-Charged Quantity	Weight	kg	2.4	
	CO ₂ equivalent	t	1.62	
Max Added Quantity	Weight	kg	2.4	
	CO ₂ equivalent	t	1.62	

*1 Energy consumption based on standard test results.
 Actual energy consumption will depend on how the appliance is used and where it is located.
 *2 If the outdoor unit is installed higher than the indoor unit, max. height is reduced to 10 m.
 *3 SEER/SCOP values and energy efficiency class are measured when connected to the indoor units listed below.
 MXZ-2F33VF5 MSZ-AY15VGK(P)2 + MSZ-LN18VG3
 MXZ-2F42VF5 MSZ-LN18VG3 + MSZ-LN25VG3
 MXZ-2F53VF5(H)5 MSZ-LN18VG3 + MSZ-LN35VG3
 MXZ-3F54VF5 MSZ-LN18VG3 + MSZ-LN18VG3 + MSZ-LN18VG3
 MXZ-3F68VF5 MSZ-LN18VG3 + MSZ-LN25VG3 + MSZ-LN25VG3
 MXZ-4F72VF5 MSZ-LN18VG3 + MSZ-LN18VG3 + MSZ-LN18VG3 + MSZ-LN18VG3
 MXZ-4F80VF5 MSZ-LN18VG3 + MSZ-LN18VG3 + MSZ-LN18VG3 + MSZ-LN25VG3
 MXZ-4F83VF3 MSZ-LN18VG3 + MSZ-LN18VG3 + MSZ-LN25VG3 + MSZ-LN25VG3
 MXZ-5F102VF3 MSZ-LN18VG3 + MSZ-LN18VG3 + MSZ-LN18VG3 + MSZ-LN25VG3 + MSZ-LN25VG3
 MXZ-6F120VF3 MSZ-LN18VG3 + MSZ-LN18VG3 + MSZ-LN18VG3 + MSZ-LN25VG3 + MSZ-LN25VG3
 *4 This GWP value is based on Regulation(EU) No 517/2014 from IPCC 4th edition.

MXZ-VFHZ SERIES

New hyper-heating MXZ allows you to create an oasis of comfort throughout your home and office in the rooms you use most, any time of the year.



Standard Rated Heating Capacity is Maintained Even When the Outdoor Temperature Drops to -15°C.

Maintains high capacity output even when outdoor temperature is low.

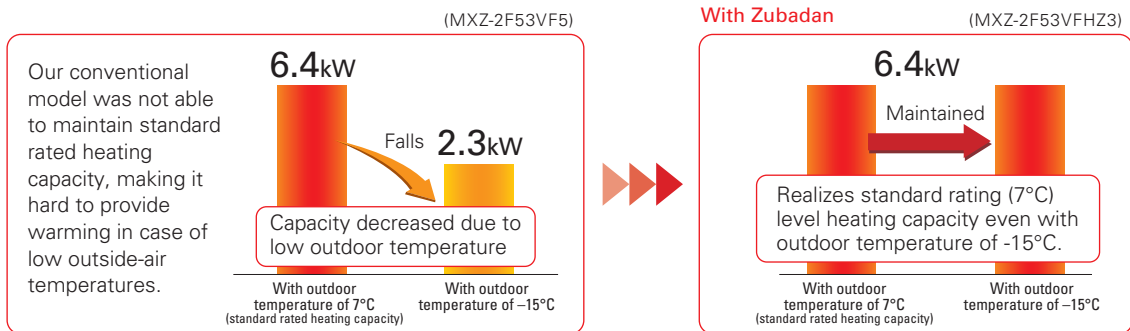

Can Operate at Outdoor Temperature of -25°C

1. Incorporated key parts resistant to cold of up to -25°C after rigorous selection.
2. Printed circuit board-core of the air conditioner—is coated on both sides to protect it in harsh environments.

Equipped Freeze-prevention Heater as Standard

Prevents capacity loss and operation from stopping due to drain water freezing.

Drain water **freezes** after operation in the harsh cold



With Hyper heating Does not freeze!

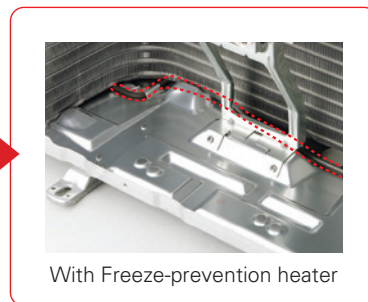
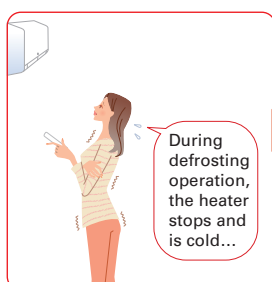

*Image is for illustration purposes. The actual performance depends on outdoor temperature.

Continuous Heating for Long Periods

Wasteful defrosting operation suppressed to enable more comfortable long-term continuous heating.

Extremely cold outside



With Hyper heating

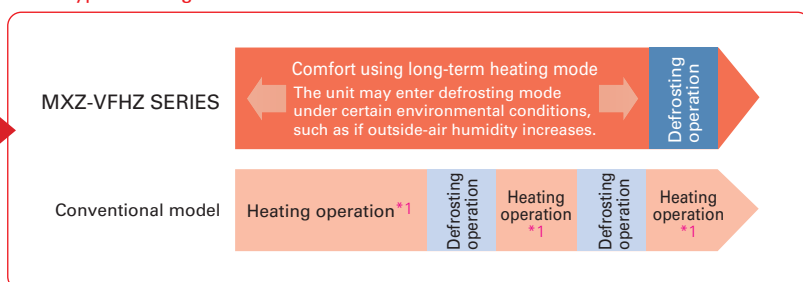

*1: Conventional model performs continuous heating approximately 30min up to a maximum of 90min.

One Outdoor Unit Supports Multiple Indoor Units.

With MXZ-VFHZ, one outdoor unit can cool and heat up to four rooms. They can be installed neatly in sites with limited space such as condominium balconies.

*Please note that cooling and heating modes cannot be run simultaneously in different rooms.

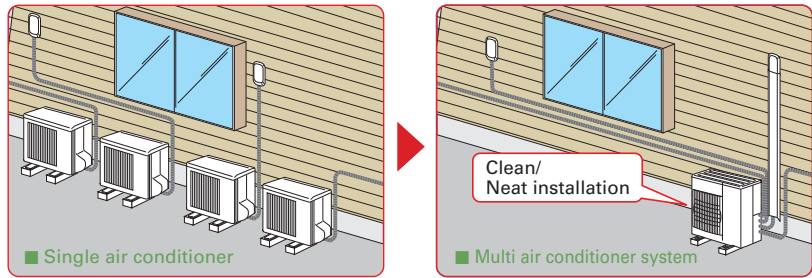

Low Noise Mode

Low Noise Mode offers a two-stage setting: 1. Single click: Only the outdoor unit operates more quietly. 2. Double click: The remote controller beep sound is turned off, the indoor unit's lamp is dimmed, and the outdoor unit operates even more quietly. We recommend using setting 1 during the day and setting 2 at night for optimal comfort.

Low Noise Mode			
Click	Remote controller Beep	Indoor unit Lamp	Outdoor unit noise
1	ON	ON	LOW
2	OFF	DIM	VERY LOW

EXAMPLE SYSTEM

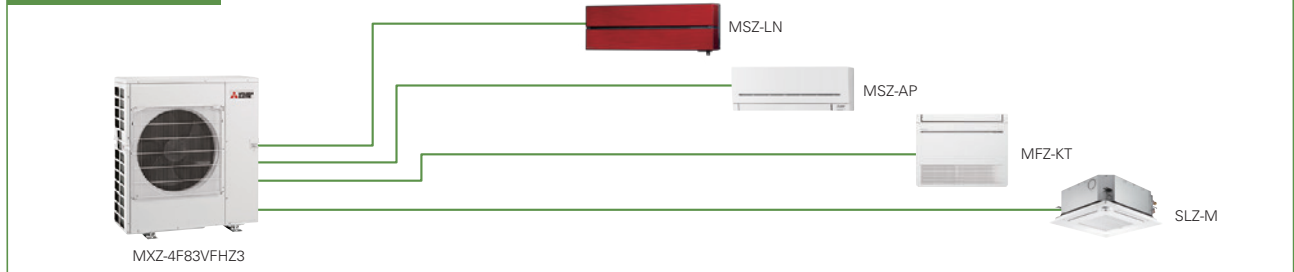

Freedom of Combinations in Cold Region Greatly Enhanced

The variety of indoor unit connection options in cold regions, restricted until now, has been greatly increased. Increased design freedom.

OUTDOOR UNITS	
<p>2-room use</p> <p>R32</p> <p>MXZ-2F53VFHZ3</p>	<p>4-room use</p> <p>R32</p> <p>MXZ-4F83VFHZ3</p>

INDOOR UNITS			
<p>Wall-mounted</p> <p>R32 R410A</p> <p>MSZ-RW</p> <p>R32 R410A</p> <p>MSZ-LN</p> <p>R32 R410A</p> <p>MSZ-AY</p> <p>R32 R410A</p> <p>MSZ-EF</p> <p>R32</p> <p>MSZ-FT</p> <p>R32</p> <p>MSZ-BT</p>	<p>Floor-standing</p> <p>R32</p> <p>MFZ-KT</p> <p>R32</p> <p>SFZ</p>	<p>Cassette</p> <p>R32 R410A</p> <p>SLZ</p> <p>R32 R410A</p> <p>MLZ-KP</p>	<p>Ceiling-concealed</p> <p>R32 R410A</p> <p>SEZ</p> <p>R32</p> <p>PEAD</p>

For specific compatible models, please refer to the "Indoor Unit Compatibility Table."

MXZ-VFHZ SERIES



Outdoor Unit

R32



MXZ-2F53VFHZ3

R32



MXZ-4F83VFHZ3

Type			Inverter Heat Pump			
Indoor Unit			Please refer to *2 *3			
Outdoor Unit			MXZ-2F53VFHZ3	MXZ-4F83VFHZ3		
Refrigerant			R32*4			
Power Supply			Outdoor power supply			
Outdoor (V/Phase/Hz)			220 - 230 - 240V / Single / 50			
Cooling	Capacity	Rated	kW	5.3	8.3	
		Min - Max	kW	1.1 - 6.0	3.5 - 9.2	
	Total Input	Rated	kW	1.29	1.90	
	Design Load		kW	5.3	8.3	
	Annual Electricity Consumption*1		kWh/a	274	398	
	SEER*5			6.8	7.3	
			Energy Efficiency Class			
			A++			
Heating (Average Season)	Capacity	Rated	kW	6.4	9.0	
		Min - Max	kW	1.0 - 7.0	3.5 - 11.6	
	Total Input	Rated	kW	1.36	1.70	
	Design Load		kW	6.4	10.1	
	Declared Capacity	at reference design temperature	kW	6.9	10.6	
		at bivalent temperature	kW	7.4	11.5	
		at operation limit temperature	kW	4.1	5.7	
	Back Up Heating Capacity		kW	0.0		
Annual Electricity Consumption*1		kWh/a	2172	3286		
SCOP*5			4.1	4.3		
			Energy Efficiency Class			
			A+			
Max. Operating Current (Indoor+Outdoor)			A	15.6	28.0	
Outdoor Unit	Dimensions	H*W*D	mm	796 × 950 × 330	1048 × 950 × 330	
	Weight		kg	60	86	
	Air Volume	Cooling		m ³ /min	43	63
		Heating		m ³ /min	41	77
	Sound Level (SPL)	Cooling		dB(A)	45	55
		Heating		dB(A)	47	57
	Sound Level (PWL)	Cooling		dB(A)	55	66
	Breaker Size		A		16	30
	Ext. Piping	Port Diameter	Liquid	mm	6.35 × 2	6.35 × 4
			Gas	mm	9.52 × 2	12.7 × 1+9.52 × 3
Total Piping Length (max)			m	30	70	
Each Indoor Unit Piping Length (max)			m	20	25	
Max. Height			m	15	15	
Chargeless Length		m	30	70		
Guaranteed Operating Range (Outdoor)	Cooling		°C	-10 ~ +46		
	Heating		°C	-25 ~ +24		
Refrigerant/GWP				R32/675*4		
Pre-Charged Quantity	Weight		kg	2.4		
	CO ₂ equivalent		t	1.62		
Max Added Quantity	Weight		kg	2.4		
	CO ₂ equivalent		t	1.62		

*1 Energy consumption based on standard test results.

Actual energy consumption will depend on how the appliance is used and where it is located.

*2 SEER/SCOP values and energy efficiency class are measured when connected to the indoor units listed below.

If the outdoor unit is installed higher than the indoor unit, max. height is reduced to 10 m

MXZ-2F53VFHZ3 MSZ-LN18VG3 + MSZ-LN35VG3

MXZ-4F83VFHZ3 MSZ-LN18VG3 + MSZ-LN18VG3 + MSZ-LN25VG3 + MSZ-LN25VG3

*3 Indoor unit compatibility table is shown on page 120.

*4 This GWP value is based on Regulation(EU) No 517/2014 from IPCC 4th edition.

MXZ-HA SERIES

Multi-port outdoor units exclusively for MSZ-HR indoor units.



R32

2-port

MXZ-2HA40VF3
MXZ-2HA50VF3



R32

3-port

MXZ-3HA50VF3

Stylish Design with Flat Panel Front

A stylish flat panel design is employed for the front of the indoor unit. The simple look matches room aesthetics.



Easy to Create Various Combinations

Wide range of simple combinations only possible using multi-port outdoor units.

Two bedrooms



Three bedrooms

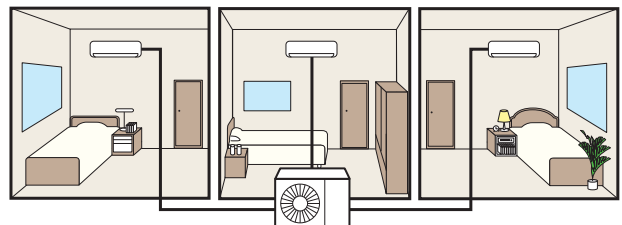

Living room and one bedroom

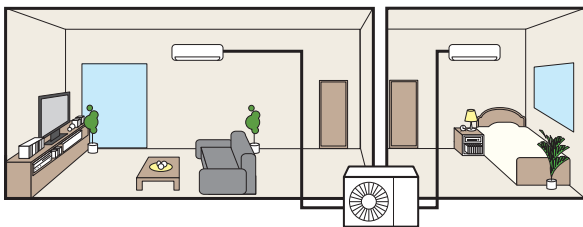

Wide living room

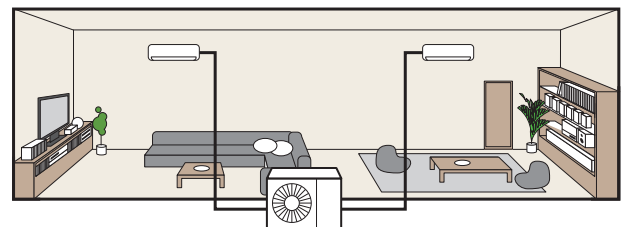

Low Noise Mode

Low Noise Mode offers a two-stage setting: 1. Single click: Only the outdoor unit operates more quietly. 2. Double click: The remote controller beep sound is turned off, the indoor unit's lamp is dimmed, and the outdoor unit operates even more quietly. We recommend using setting 1 during the day and setting 2 at night for optimal comfort.

Low Noise Mode			
Click	Remote controller Beep	Indoor unit Lamp	Outdoor unit noise
1	ON	ON	LOW
2	OFF	DIM	VERY LOW

MXZ-HA SERIES

INVERTER MULTI



Type (Inverter Multi - Split Heat Pump)				Up to 2 Indoor Units		Up to 3 Indoor Units	
Indoor Unit				Please refer to*3			
Outdoor Unit				MXZ-2HA40VF3		MXZ-2HA50VF3	
Refrigerant				R32			
Power Supply				Outdoor power supply			
Source				220 - 230 - 240V / Single / 50Hz			
Outdoor (V/Phase/Hz)							
Cooling	Capacity	Rated	kW	4.0	5.0		
		Min-Max	kW	1.1 - 4.3	1.1 - 5.4	2.9 - 6.5	
	Input	Rated	kW	1.05	1.52	1.26	
	Design Load		kW	4.0	5.0		
	Annual Electricity Consumption*2		kWh/a	172	225	241	
	SEER*1		8.1	7.8	7.3		
	Energy Efficiency Class*3			A++			
Heating	Capacity	Rated	kW	4.3	6.0		6.0
		Min-Max	kW	1.0 - 4.7	1.0 - 6.4	2.6 - 7.5	
	Input	Rated	kW	0.91	1.54	1.30	
	Design Load		kW		3.2	4.0	
	Declared Capacity	at reference design temperature		kW	2.4	3.0	
		at bivalent temperature		kW	2.9	3.6	
		at operation limit temperature		kW	2.1	2.6	
	Back Up Heating Capacity		kW	0.8	1.0		
	Annual Electricity Consumption*2		kWh/a	1043	1394		
		SCOP*3		4.3	4.0		
	Energy Efficiency Class*3			A+			
Max. Operating Current (Indoor+Outdoor)			A	12.2	18.0		
Outdoor Unit	Dimensions		H*W*D	550 - 800 (+69) - 285 (+59.5)		710 - 840 - 330 (+66)	
	Weight		kg	37		57	
	Air Volume	Cooling	m ³ /min	28.4	32.7	31.0	
		Heating	m ³ /min	33.5	34.7	29.1	
	Sound Level (SPL)	Cooling	dB(A)	44	47	46	
		Heating	dB(A)	50	51	50	
	Sound Level (PWL)	Cooling	dB(A)	59	64	61	
	Breaker Size		A	15		25	
Ext. Piping	Port Diameter	Liquid	mm	6.35 × 2			
		Gas	mm	9.52 × 2			
	Total Piping Length (max)		m	30		50	
	Each Indoor Unit Piping Length (max)		m	20		25	
	Max. Height		m	15(10)*2			
Chargeless Length		m	30		40		
Guaranteed Operating Range [Outdoor]	Cooling	°C	-10 ~ +46				
	Heating	°C	-15 ~ +24				
Refrigerant/GWP				R32/675*4			
Pre-Charged Quantity	Weight	Kg	0.9		1.4		
	CO ₂ equivalent	t	0.61		0.95		
Max Added Quantity	Weight	Kg	0.9		1.6		
	CO ₂ equivalent	t	0.61		1.08		

*1 Energy consumption based on standard test results.
 Actual energy consumption will depend on how the appliance is used and where it is located.
 *2 If the outdoor unit is installed higher than the indoor unit, max. height is reduced to 10 m.
 *3 SEER/SCOP values and energy efficiency class are measured when connected to the indoor units listed below.
 MXZ-2HA40VF3 → MSZ-HR25VF2 + MSZ-HR25VF2
 MXZ-2HA50VF3 → MSZ-HR25VF2 + MSZ-HR25VF2
 MXZ-3HA50VF3 → MSZ-HR25VF2 + MSZ-HR25VF2 + MSZ-HR25VF2
 *4 This GWP value is based on Regulation(EU) No 517/2014 from IPCC 4th edition,

To ensure full capacity in cold and snowy regions...

3 Important Points to Remember When Installing the Outdoor Unit



*RAC/PAC (inc. Air to Water) /MXZ

Wind and snow can significantly reduce capacity.

Be sure to check the information below and install the outdoor unit correctly.

1 Installation Location

Be aware of the prevailing wind direction in winter and install the outdoor unit where it is as sheltered as possible.

Units are easily affected by wind and unit may not be able to run at full capacity

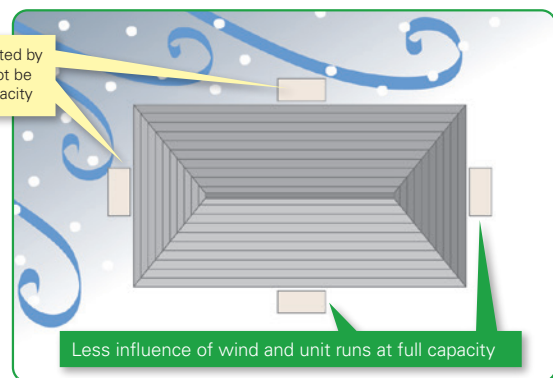

2 Measures for Drainage of Water

Case 1: Unit is installed close to passage (walkway)

To prevent freezing and potential falls, install the unit where Drainage of Water will not flow onto walkways.

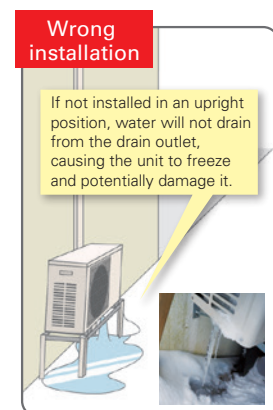
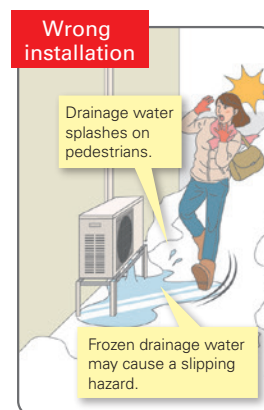
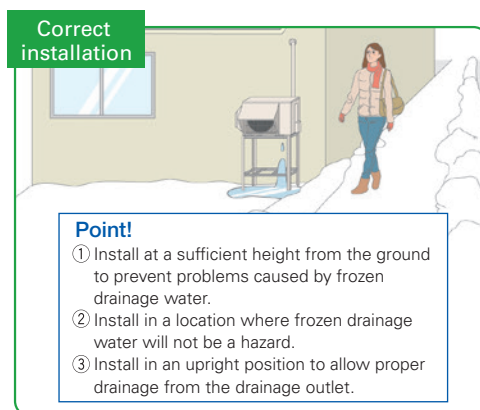

Case 2: Multiple units are installed

Do not install units on top of one another as it may cause frozen drainage water on the bottom unit.

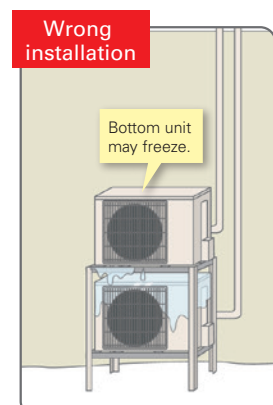
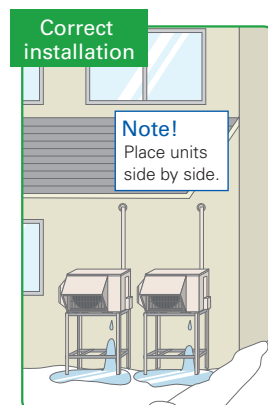

3

Measures for Snow

Unit is installed on the ground

To avoid the adverse effects of snow and frozen drainage water, install the unit on a stand to ensure a sufficient height from the ground.

[RAC / PAC / MXZ]

Correct installation

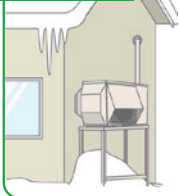

Point!

- ① Install at a position/height to prevent the unit being buried in snow*1 and the adverse effects of frozen drainage water.*2
- ② Install so as to avoid the effects of snow or snowdrift.
- ③ Install so as to avoid the damage from falling snow or icicles.

*1 Install at a height above the highest snowfall depth.
*2 Even for correct installations, dripping drainage water may form an icicle which needs to be cleared away regularly to prevent a blocked drainage outlet.

Wrong installation

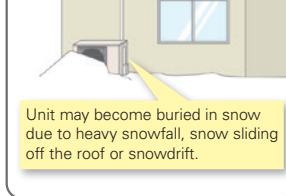

Unit may become buried in snow due to heavy snowfall, snow sliding off the roof or snowdrift.

Wrong installation

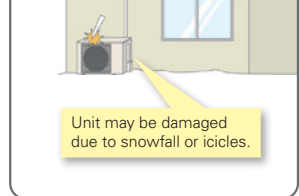

Unit may be damaged due to snowfall or icicles.

Use a stand to add sufficient height to protect the unit heat exchanger from snow and prevent icicles forming during defrost operation.

Install snow protection hood as necessary

[RAC / PAC / MXZ]

Correct installation

Minimum height (h) should be higher than the highest snowfall depth (h0) **+20cm**

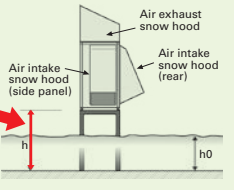

Wrong installation

Unit may become covered in snow if the stand height is insufficient.

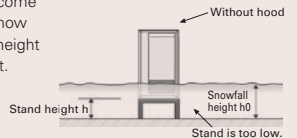

Correct installation

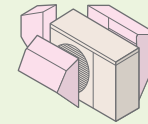

Point!

Install the snow protection hood or other cover in snowy regions.

Necessity of accessories (drain socket & centralised drain pan, stand, snow protection hood, base heater)

	Snowy region	Cold region	Remarks
	Countermeasures for snow	Countermeasures for freezing	
Drain socket, Centralised drain pan	Not used	Not used	Prevents freezing
Stand	Needed	Needed	[RAC / PAC / MXZ] 1. Install so as to prevent the unit being buried in snow (at a height greater than the highest snowfall depth). Be sure that the stand does not obstruct drainage. 2. Install so as to prevent damage to the unit due to frozen drainage water (icicles). 
Snow protection hood	Needed *When the installation position is subject to snowfall.	—	1. Prevents heat exchanger from being covered in snow. 2. Prevents snow accumulating inside the air duct.
Base heater	—	Needed	[RAC / PAC / MXZ] The outdoor unit with heater for cold regions has the model name "V*H". For the cold-climate zone, use of a unit with a heater is strongly recommended. Even for the moderate-climate zone use of a unit with a heater is recommended for regions subject to high humidity in winter.

About disposal of drainage water

CAUTION

When the unit is installed in cold or snowy regions :

Drainage water may freeze in the drain socket/hose and prevent the fan from rotating.



Do not attach a drain socket packaged as an accessory to the unit.

* In the case that fitting a drain socket is absolutely necessary, steps must be taken so that the drainage water does not freeze.
For more information, please consult Mitsubishi Electric or one of its dealers/resellers.

Arrangement for snow protection hood

[RAC / PAC / MXZ]

Separately sold parts are available for some models.

Please consult Mitsubishi Electric or one of its dealers/resellers at the time of purchase for details.

Indoor Unit Compatibility Table

■ MXZ Series R32

Possible combinations of outdoor units and indoor units are shown below.

Indoor Unit		Outdoor Unit	Inverter Models Heat Pump Type															
			MXZ ⁻¹ 2F33VF5	MXZ ⁻¹ 2F42VF5	MXZ ⁻¹ 2F53VF(H)5	MXZ ⁻¹ 2F53VFHZ3	MXZ ⁻¹ 3F54VF5	MXZ ⁻¹ 3F68VF5	MXZ ⁻¹ 4F72VF5	MXZ ⁻¹ 4F80VF5	MXZ ⁻ 4F83VF3	MXZ ⁻ 4F83VFHZ3	MXZ ⁻ 5F102VF3	MXZ ⁻ 6F120VF3	MXZ ⁻¹ 2HA40VF3	MXZ ⁻¹ 2HA50VF3	MXZ ⁻¹ 3HA50VF3	
M series	Wall-Mounted	MSZ-RZ25VU																
		MSZ-RZ35VU																
		MSZ-RZ50VU																
		MSZ-RW25VG2	●	●	●	●	●	●	●	●	●	●	●	●				
		MSZ-RW35VG2		●	●	●	●	●	●	●	●	●	●	●				
		MSZ-RW50VG2																
		MSZ-LN18VG3(W)(V)(R)(B)	●	●	●	●	●	●	●	●	●	●	●	●				
		MSZ-LN25VG3(W)(V)(R)(B)	●	●	●	●	●	●	●	●	●	●	●	●				
		MSZ-LN35VG3(W)(V)(R)(B)		●	●	●	●	●	●	●	●	●	●	●				
		MSZ-LN50VG3(W)(V)(R)(B)																
		MSZ-FT25VG2				●												
		MSZ-FT35VG2				●												
		MSZ-FT50VG2																
		MSZ-AY15VGK(P)2	●	●	●	●	●	●	●	●	●	●	●	●				
		MSZ-AY20VGK(P)2	●	●	●	●	●	●	●	●	●	●	●	●				
		MSZ-AY25VGK(P)2	●	●	●	●	●	●	●	●	●	●	●	●				
		MSZ-AY35VGK(P)2		●	●	●	●	●	●	●	●	●	●	●				
		MSZ-AY42VGK(P)2			●	●	●	●	●	●	●	●	●	●				
		MSZ-AY50VGK(P)2			●	●	●	●	●	●	●	●	●	●				
		MSZ-AP60VG(K)2						●	●	●	●	●	●	●				
		MSZ-AP71VG(K)2						●	●	●	●	●	●	●				
		MSZ-EF18VG2(K)(W)(B)(S)	●	●	●	●	●	●	●	●	●	●	●	●				
		MSZ-EF22VG2(K)(W)(B)(S)	●	●	●	●	●	●	●	●	●	●	●	●				
		MSZ-EF25VG2(K)(W)(B)(S)	●	●	●	●	●	●	●	●	●	●	●	●				
		MSZ-EF35VG2(K)(W)(B)(S)		●	●	●	●	●	●	●	●	●	●	●				
		MSZ-EF42VG2(K)(W)(B)(S)			●	●	●	●	●	●	●	●	●	●				
		MSZ-EF50VG2(K)(W)(B)(S)				●	●	●	●	●	●	●	●	●				
		MSZ-BT20VG(K)2	●	●	●	●	●	●	●	●	●	●	●	●				
		MSZ-BT25VG(K)2	●	●	●	●	●	●	●	●	●	●	●	●				
		MSZ-BT35VG(K)2		●	●	●	●	●	●	●	●	●	●	●				
		MSZ-BT50VG(K)2																
		MSZ-HR25VF(K)2														●	●	●
		MSZ-HR35VF(K)2														●	●	●
MSZ-HR42VF(K)2															●	●		
MSZ-HR50VF(K)2																●		
MSZ-HR60VF(K)2																		
MSZ-HR71VF(K)2																		
MSZ-DW25VF														●	●	●		
MSZ-DW35VF														●	●	●		
MSZ-DW50VF																		
Floor-Standing	MFZ-KT25VG	●	●	●	●	●	●	●	●	●	●	●						
	MFZ-KT35VG		●	●	●	●	●	●	●	●	●	●						
	MFZ-KT50VG																	
1-way Cassette	MLZ-KP25VF	●	●	●	●	●	●	●	●	●	●	●						
	MLZ-KP35VF		●	●	●	●	●	●	●	●	●	●						
	MLZ-KP50VF																	
MLZ-KY20VG	●	●	●	●	●	●	●	●	●	●	●	●						
S series	2×2 Cassette	SLZ-M15FA3	●	●	●	●	●	●	●	●	●	●	●					
		SLZ-M25FA3	●	●	●	●	●	●	●	●	●	●	●					
		SLZ-M35FA3		●	●	●	●	●	●	●	●	●	●					
		SLZ-M50FA3						●	●	●	●	●	●					
		SLZ-M60FA3						●	●	●	●	●	●					
	Ceiling-Concealed	SEZ-M25DA3 *2	●	●	●	●	●	●	●	●	●	●	●					
		SEZ-M35DA3		●	●	●	●	●	●	●	●	●	●					
		SEZ-M50DA3					●	●	●	●	●	●	●					
		SEZ-M60DA3						●	●	●	●	●	●					
		SEZ-M71DA3							●	●	●	●	●					
Concealed Floor-Standing	SFZ-M25VA2	●	●	●	●	●	●	●	●	●	●	●						
	SFZ-M35VA2		●	●	●	●	●	●	●	●	●	●						
	SFZ-M50VA2						●	●	●	●	●	●						
	SFZ-M60VA2							●	●	●	●	●						
	SFZ-M71VA2								●	●	●	●						
P series	Ceiling-Suspended	PCA-M50KA3					●	●	●	●								
		PCA-M60KA3						●	●	●								
		PCA-M71KA3							●	●	●							
	Ceiling-Concealed	PEAD-M35JA3		PEAD35	PEAD35	●*3	●*3	●*3	●*3	●*3	●*3	●*3	●*3					
		PEAD-M35JAL3		PEAD35	PEAD35	●*3	●*3	●*3	●*3	●*3	●*3	●*3	●*3					
		PEAD-M50JA3				●*3	●*3	●*3	●*3	●*3	●*3	●*3	●*3					
		PEAD-M50JAL3				●*3	●*3	●*3	●*3	●*3	●*3	●*3	●*3					
		PEAD-M60JA3									●*3	●*3	●*3					
		PEAD-M60JAL3									●*3	●*3	●*3					
		PEAD-M71JA3									●*3	●*3	●*3					
PEAD-M71JAL3									●*3	●*3	●*3							

*1 MXZ outdoor units are not designed to operate with a single indoor unit with one-to-one piping work. Please install at least two indoor units.
 *2 SEZ-M25 cannot be connected with MXZ-2F/3F/4F when total capacity of connected indoor units is equivalent to outdoor capacity (capacity ratio is 1).
 *3 Maximum total current of indoor units: 3A or less *4 P series cannot be connected with MXZ-4F83VFHZ2 when ampere limit adjustment function is operated.

















VRF











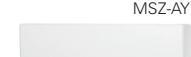
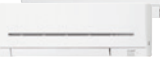

SERIES



SELECTION

Choose from types of indoor units and outdoor units.
Create the system that best matches room shapes and number of rooms.

R410A INDOOR UNITS		R410A OUTDOOR UNITS	
Wall-mounted  MSZ-LN  MSZ-EF  MSZ-AY  MSZ-AP  MSZ-AP  MSZ-BT	Floor-standing  MFZ-KT	PUMY-SP  SP112/125/140V(Y)KM2	
	Ceiling-suspended  PCA	PUMY-P  P200YKM4  P250/300YBM3	
Cassette  SLZ  MLZ-KP  MLZ-KY	Ceiling-concealed  SEZ  PEAD		

R32 INDOOR UNITS		R32 OUTDOOR UNITS	
Wall-mounted  MSZ-LN  MSZ-EF  MSZ-AY  MSZ-AP  MSZ-RW  MSZ-BT	Ceiling-suspended  PCA	PUMY-SM  SM112/125/140V(Y)KM	
Cassette  SLZ  MLZ-KP  MLZ-KY	Ceiling-concealed  SEZ  PEAD	PUMY-M  M200YKM	

CHECK SYSTEM COMPATIBILITY

Possible combinations depends on the outdoor unit chosen. Please check the following points.

Check Indoor Units

Refer to the "Indoor Unit Compatibility Table" to check if the indoor units selected can be used with the outdoor unit selected. (Indoor units not listed in the table cannot be used.)

Check Indoor Unit Capacity Combination

Refer to the "Combination Table" to check if the capacity combination of the indoor unit selected is connectable. (Combinations not listed cannot be connected.)

If the desired combination cannot be found, please change either the indoor or outdoor unit to match one of the combinations shown in the tables.

PUMY-SP SERIES

Air conditioning system supports replacement work by simplifying the installation process. Ideal for supporting renewal needs at small offices and stores, home offices, etc.



R410A

PUMY-SP112/125/140VKM2
PUMY-SP112/125/140YKM2

EXAMPLE SYSTEM

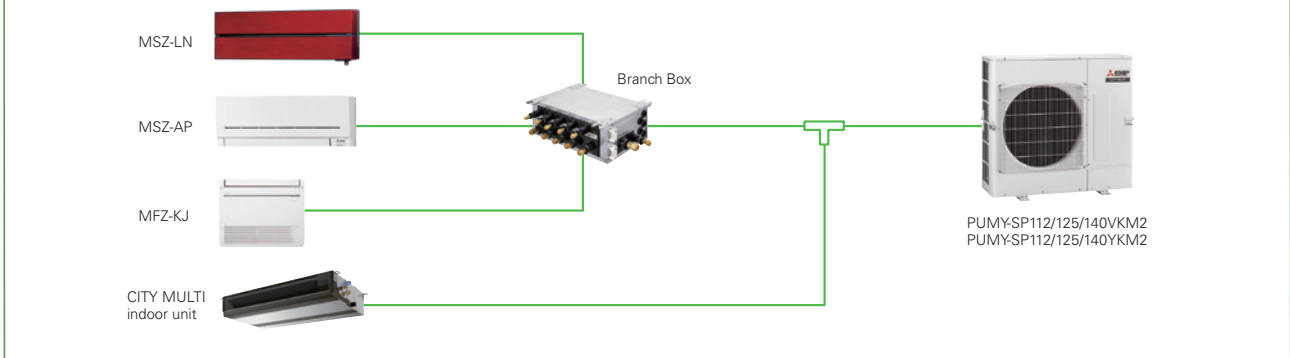

Light Weight and Compact Size

Compact design fits into narrow outdoor unit space of condominiums and offices. Light weight design facilitates easy installation and transportation.

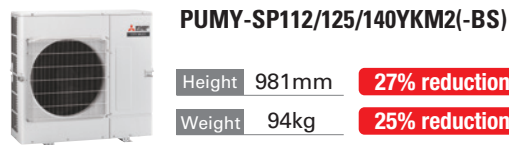
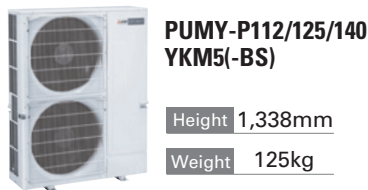

Unobstructive, compact, and easy to hide from view

Conventional 2-fan type outdoor units may spoil the view. Due to its compact size, the new outdoor fan unit can be installed in locations that would have been inappropriate.

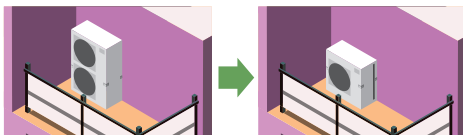

Easy installation and transportation

The reduced weight and height allow for better transportation performance. Carrying and installing become easier.

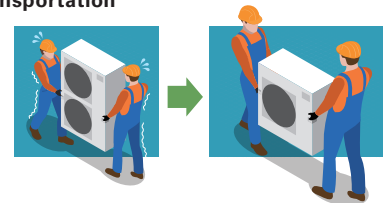

Industry's Top Energy Efficiency

Even with its compact size and light weight, it has a high EER and COP. Costs are reduced with the industry's best energy saving abilities.

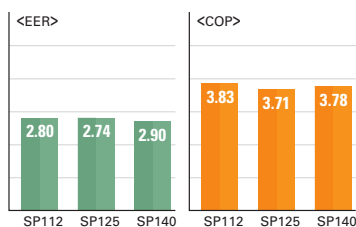

An External Static Pressure of 30Pa

The installation location is flexible, thanks to its 30Pa static pressure. You can install it in locations that you could not before.

An external static pressure of 30Pa allows outdoor unit to be installed on balconies in high-rise building or spaces near louvers.

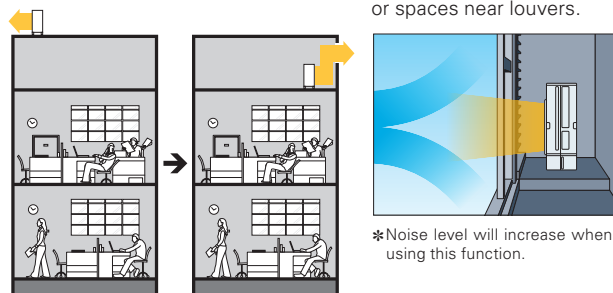

Super Silent Mode*

Noise level can be reduced up to 10dB(A). This allows you to operate the unit even in the night in a residential zone.

*Capacity reduction differs by mode setting.

*PAC-SC36NA-E is required to activate Super Silent mode.

Rear Piping is Available

Freedom with layout due to its piping pullout locations in four directions

The in-door unit allows piping from any four directions; front, back, bottom, or right. This enables easier horizontal connection for collective layout.

The out-door unit with an expanded piping layout flexibility greatly improves piping workability.

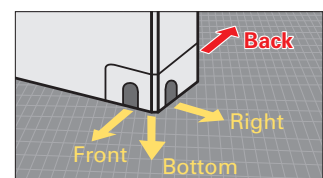

PUMY-SP SERIES

INVERTER MULTI



Model		PUMY-SP112VKM2 (-BS)	PUMY-SP125VKM2 (-BS)	PUMY-SP140VKM2 (-BS)	PUMY-SP112YKM2 (-BS)	PUMY-SP125YKM2 (-BS)	PUMY-SP140YKM2 (-BS)	
Power Source		1-phase 220-230-240V 50Hz, 220V 60Hz			3-phase 380-400-415V 50Hz, 380V 60Hz			
Cooling Capacity (Nominal)	Power Input	12.5	14.0	15.5	12.5	14.0	15.5	
	Current Input	4.46	5.11	5.34	4.46	5.11	5.34	
	EER	20.69 - 19.79 - 18.97, 20.69	23.71 - 22.68 - 21.73, 23.71	24.77 - 23.70 - 22.71, 24.77	7.14 - 6.78 - 6.54, 7.14	8.18 - 7.77 - 7.49, 8.18	8.55 - 8.12 - 7.83, 8.55	
	EER	2.80	2.74	2.90	2.80	2.74	2.90	
Temp. Range of Cooling	Indoor Temp.	15.0~24.0°C (59~75°F)	15.0~24.0°C (59~75°F)	15.0~24.0°C (59~75°F)	15.0~24.0°C (59~75°F)	15.0~24.0°C (59~75°F)	15.0~24.0°C (59~75°F)	
	Outdoor Temp.	D.B. -5.0~52.0°C (23~126°F)	-5.0~52.0°C (23~126°F)	-5.0~52.0°C (23~126°F)	-5.0~52.0°C (23~126°F)	-5.0~52.0°C (23~126°F)	-5.0~52.0°C (23~126°F)	
Heating Capacity (Nominal)	Power Input	14.0	16.0	16.5	14.0	16.0	16.5	
	Current Input	3.66	4.31	4.36	3.66	4.31	4.36	
	COP	16.98 - 16.24 - 15.57, 16.98	20.00 - 19.13 - 18.33, 20.00	20.23 - 19.35 - 18.54, 20.23	5.86 - 5.57 - 5.36, 5.86	6.90 - 6.55 - 6.32, 6.90	6.98 - 6.63 - 6.39, 6.98	
	COP	3.83	3.71	3.78	3.83	3.71	3.78	
Temp. Range Of Heating	Indoor Temp.	D.B. 15.0~27.0°C (59~81°F)	15.0~27.0°C (59~81°F)	15.0~27.0°C (59~81°F)	15.0~27.0°C (59~81°F)	15.0~27.0°C (59~81°F)	15.0~27.0°C (59~81°F)	
	Outdoor Temp.	W.B. -20.0~15.0°C (-4~59°F)	-20.0~15.0°C (-4~59°F)	-20.0~15.0°C (-4~59°F)	-20.0~15.0°C (-4~59°F)	-20.0~15.0°C (-4~59°F)	-20.0~15.0°C (-4~59°F)	
Indoor Unit Connectable	Total Capacity	50-130 % of outdoor unit capacity			50-130 % of outdoor unit capacity			
	Model / Quantity	City Multi*4 Branch Box*5	10-140/12 15-100/8	10-140/12 15-100/8	10-140/12 15-100/8	10-140/12 15-100/8	10-140/12 15-100/8	
Sound Pressure Level (Measured In Anechoic Room)	Mixed System	Branch Box*1 unit	10-140/5 15-100/5	10-140/5 15-100/5	10-140/5 15-100/5	10-140/5 15-100/5	10-140/5 15-100/5	
	Branch Box*2 units	City Multi	10-140/3 15-100/8	10-140/3 15-100/8	10-140/3 15-100/8	10-140/3 15-100/8	10-140/3 15-100/8	
		Branch Box*3	15-100/5 15-100/5	15-100/5 15-100/5	15-100/5 15-100/5	15-100/5 15-100/5	15-100/5 15-100/5	
	Sound Power Level (Measured In Anechoic Room)	dB <A>	52/54	53/56	54/56	52/54	53/56	54/56
Refrigerant Piping Diameter	Liquid Pipe	9.52 (3/8)	9.52 (3/8)	9.52 (3/8)	9.52 (3/8)	9.52 (3/8)	9.52 (3/8)	
Fan	Gas Pipe	15.88 (5/8)	15.88 (5/8)	15.88 (5/8)	15.88 (5/8)	15.88 (5/8)	15.88 (5/8)	
	Type x Quantity	Propeller Fan x 1						
	Air Flow Rate	m ³ /min	77	83	83	77	83	83
	Motor Output	kW	0.20 x 1	0.20 x 1	0.20 x 1	0.20 x 1	0.20 x 1	0.20 x 1
Compressor	External Static Press.	0Pa / 30Pa*6						
	Type x Quantity	Twin rotary hermetic compressor x 1						
Starting Method	Inverter							
	Motor Output	kW	3.9	3.9	4.2	3.9	3.8	4.1
External dimension H*W*D	mm	981 x 1,050 x 330 (+40)						
	in.	38-5/8 x 41-3/8 x 13 (+1-3/64)						
Net Weight	kg (lbs)	93 (205)*7			94 (207)*8			

*1,*3 Nominal conditions

	Indoor	Outdoor	Piping Length	Level Difference	External Static Press. (Outdoor Unit)
Cooling	27°C DB / 19°C WB	35°C	7.5m (24 - 9 / 16ft.)	0m (0ft)	0 Pa
Heating	20°C DB	7°C DB / 6°C WB	7.5m (24 - 9 / 16ft.)	0m (0ft)	0 Pa

*2 10 to 52°C; in case of connecting PKFY-P15/P20/P25VBM, PKFY-P10/15/20/25/32VLM, PFFY-P20/P25/P32VKM, PFFY-P20/25/32VCM, PFFY-P20/P25/P32VLE(R)M indoor unit and M series indoor unit with connection kit and M series, S series, and P series type indoor unit with branch box.

*4 It is possible to connect 1 Fresh Air type indoor unit to 1 outdoor unit. (1:1 system)

*5 At least 2 indoor units must be connected when using branch box.

*6 0 Pa as initial setting

*7 94 (207), for PUMY-SP112/125/140YKM2-BS

*8 95 (209), for PUMY-SP112/125/140YKM2-BS

Type	Branch Box	
Model Name	PAC-MK54BC	PAC-MK34BC
Connectable Number of Indoor Units	Maximum 5	Maximum 3
Power Supply (from outdoor unit)	~ / N, 220 / 230 / 240 V, 50 Hz, ~ / N, 220 / 230 V, 60 Hz	
Input	kW 0.003	
Running Current	A 0.05 (Max. 6)	
Dimensions	H*W*D mm 170 x 450 x 280	
Weight	kg 7.4 / 6.7	
Piping Connection (Flare)	Branch (Indoor Side)	Liquid mm ø6.35 x 5
		Gas mm ø9.52 x 4, ø12.7 x 1
	Main (Outdoor Side)	Liquid mm ø9.52
		Gas mm ø15.88

* The piping connection size differs according to the type and capacity of outdoor/indoor units. Match the piping connection size of branch box with outdoor/indoor unit. If the piping connection size of branch box does not match the piping connection size of outdoor/indoor unit, use optional different-diameter (deformed) joints to the branch box side. (Connect deformed joint directly to the branch box side.)

<Branch box compatible table>

Outdoor unit	Branch box	PAC-MK31/51BC(B)	PAC-MK32/52BC(B)	PAC-MK33/53BC(B)	PAC-MK33/54BC
Outdoor unit 1fan	PUMY-SP112/125/140V/YKM2(-BS)	N/A	N/A	✓*	✓*
Outdoor unit 2fan	PUMY-P112/125/140YKM7(-BS)	N/A	N/A	✓	✓
	PUMY-P112/125/140YKM7(-BS)	N/A	N/A	✓	✓
	PUMY-P200YKM4(-BS)	N/A	N/A	✓*	✓*
	PUMY-P250/300YBM3(-BS)	N/A	N/A	✓*	✓*

*ecodan is NG

[SP112-140V/YKM2(-BS)]

Refrigerant Piping Lengths	Maximum meters	Vertical differentials between units	Maximum meters
Total length	120	Indoor/outdoor (outdoor higher)	50
Maximum allowable length	To City Multi indoor unit: 70	Indoor/outdoor (outdoor lower)	30
	Through Branch box: 80	Indoor/indoor	15*

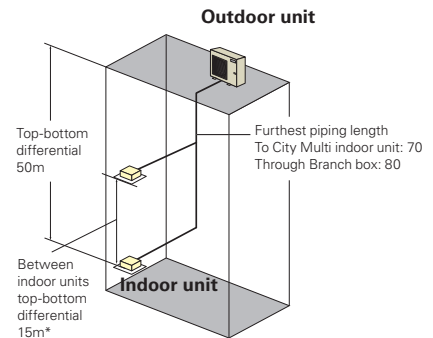

*In case of branch box connection: 12m

PUMY-P SERIES

Air conditioning system supports replacement work by simplifying the installation process. Ideal for supporting renewal needs at small offices and stores, home offices, etc.



R410A

PUMY-P112/125/140VKM7
PUMY-P112/125/140YKM7
PUMY-P200YKM4
PUMY-P250/300YBM3

EXAMPLE SYSTEM

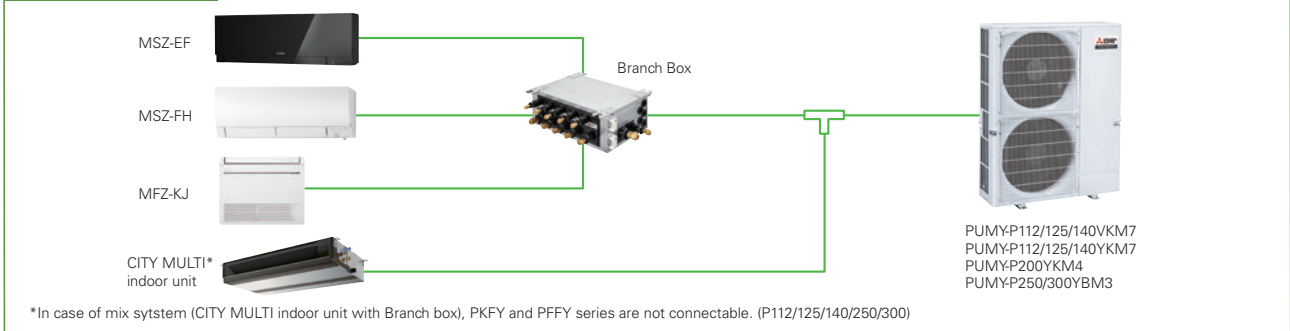

The Two-pipe Zoned System Designed for Heat Pump Operation

PUMY series make use of a two-pipe refrigerant system, which allows for system changeover from cooling to heating, ensuring that a constant indoor climate is maintained in all zones. The compact outdoor unit utilizes R410A refrigerant and an INVERTER-driven compressor to use energy effectively.

With a wide range of indoor unit line-up in connection with a flexible piping system, PUMY series can be configured for all applications. Up to 12 (P250/300: Up to 30) indoor units can be connected with up to 130% connected capacity to maximize engineer's design options. This feature allows easy air conditioning in each area with convenient individual controllers.

Small Offices

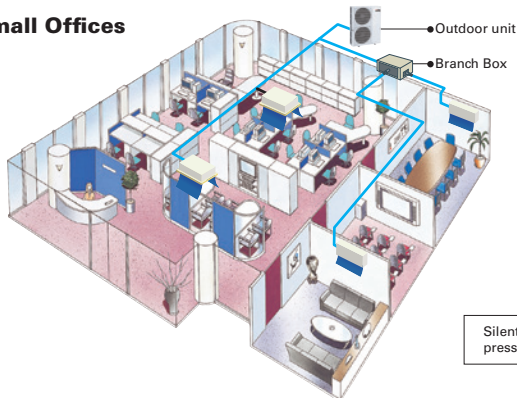

Residence

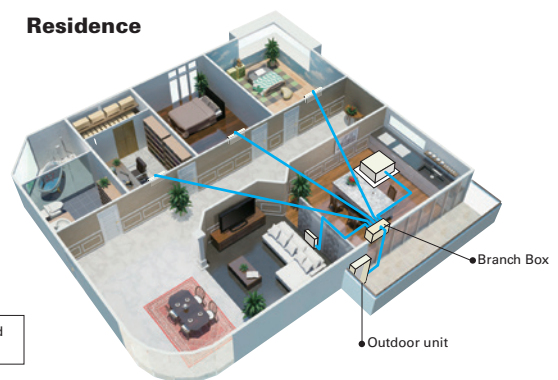

Silent mode can reduce sound pressure level by 3dB(A)

		Maximum Meters			
		Only City Multi*1 Indoor Unit	Only Branch Box Connection	Mixed System (City Multi*1 Indoor Unit + Branch Box)	
P112/125/140	Refrigerant Piping Length	Total Length	300	150	240 (2 Branch boxes) / 300 (1 Branch box)
		Maximum Allowable Length	150 (175 equivalent)	80	85 (95 equivalent)
		Farthest Indoor From First Branch	30	30	30
		Piping Length Between Outdoor Unit and Branch Boxes	55	55	55
	Vertical Differentials Between Units	Indoor/Outdoor (Outdoor higher)	50	50	50
		Indoor/Outdoor (Outdoor Lower)	40*2	40	40
		Indoor/Indoor	15	12	12
P200	Refrigerant Piping Length	Total Length	150	150	150
		Maximum Allowable Length	80 (90 equivalent)	80	80 (90 equivalent)
		Farthest Indoor From First Branch	30	30	30
		Piping Length Between Outdoor Unit and Branch Boxes	55	55	55
	Vertical Differentials Between Units	Indoor/Outdoor (Outdoor higher)	50	50	50
		Indoor/Outdoor (Outdoor Lower)	40	40	40
		Indoor/Indoor	15	12	12
P250/300	Refrigerant Piping Length	Total Length	310	240	310
		Maximum Allowable Length	150 (175 equivalent)	80	85 (95 equivalent)
		Farthest Indoor From First Branch	50	50	50
		Piping Length Between Outdoor Unit and Branch Boxes	95	95	95
	Vertical Differentials Between Units	Indoor/Outdoor (Outdoor higher)	50	50	50
		Indoor/Outdoor (Outdoor Lower)	40	40	40
		Indoor/Indoor	15	12	12

*1 Include system with connection kit *2 In case of including PKFY or PFFY, height between units is 30m.

30Pa External Static Pressure* Option (requires PAC-SJ71FM-E)

An external static pressure of 30Pa enables the outdoor unit to be installed on balconies in high-rise building or spaces near louvers.

* PUMY-P112/125/140VKM7(-BS), PUMY-P112/125/140YKM7(-BS) only.
* Noise level will increase when using this function.

30Pa external static pressure fan motor (option)
(PAC-SJ71FM-E)

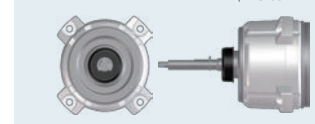

PUMY-P SERIES
INVERTER MULTI



Model		PUMY-P112VKM7 (-BS)	PUMY-P125VKM7 (-BS)	PUMY-P140VKM7 (-BS)	PUMY-P112YKM7 (-BS)	PUMY-P125YKM7 (-BS)	PUMY-P140YKM7 (-BS)	PUMY-P200YKM4 (-BS)	PUMY-P250YBM3 (-BS)	PUMY-P300YBM3 (-BS)	
Power Source		1-phase 220-230-240V 50Hz, 220-230V 60Hz			3-phase 380-400-415V 50Hz, 380V 60Hz			3-phase 380-400-415V 50Hz			
Cooling Capacity (Nominal)	Power Input	kW	12.5	14.0	15.5	12.5	14.0	15.5	22.4	28.0	33.5
	Current Input	A	4.34	5.00	5.17	4.34	5.00	5.17	7.18	8.21	11.96
	EER	kW/kW	2.88	2.80	3.00	2.88	2.80	3.00	3.12	3.41	2.80
Temp. Range of Cooling	Indoor Temp.	W.B.	15.0-24.0°C (59-75°F)	15.0-24.0°C (59-75°F)	15.0-24.0°C (59-75°F)	15.0-24.0°C (59-75°F)	15.0-24.0°C (59-75°F)	15.0-24.0°C (59-75°F)	15.0-24.0°C (59-75°F)	15.0-24.0°C (59-75°F)	15.0-24.0°C (59-75°F)
	Outdoor Temp.	D.B.	-5.0-52.0°C (23-126°F)	-5.0-52.0°C (23-126°F)	-5.0-52.0°C (23-126°F)	-5.0-52.0°C (23-126°F)	-5.0-52.0°C (23-126°F)	-5.0-52.0°C (23-126°F)	-5.0-52.0°C (23-126°F)	-5.0-52.0°C (23-126°F)	-5.0-52.0°C (23-126°F)
Heating Capacity (Nominal)	Power Input	kW	14.0	16.0	18.0	14.0	16.0	18.0	25.0	31.5	37.5
	Current Input	A	3.49	4.06	4.63	3.49	4.06	4.63	5.85	7.24	8.33
	COP	kW/kW	4.01	3.94	3.89	4.01	3.94	3.89	4.27	4.35	4.50
Temp. Range of Heating	Indoor Temp.	D.B.	15.0-27.0°C (59-81°F)	15.0-27.0°C (59-81°F)	15.0-27.0°C (59-81°F)	15.0-27.0°C (59-81°F)	15.0-27.0°C (59-81°F)	15.0-27.0°C (59-81°F)	15.0-27.0°C (59-81°F)	15.0-27.0°C (59-81°F)	15.0-27.0°C (59-81°F)
	Outdoor Temp.	W.B.	-20.0-15.0°C (4-59°F)	-20.0-15.0°C (4-59°F)	-20.0-15.0°C (4-59°F)	-20.0-15.0°C (4-59°F)	-20.0-15.0°C (4-59°F)	-20.0-15.0°C (4-59°F)	-20.0-15.0°C (4-59°F)	-20.0-15.0°C (4-59°F)	-20.0-15.0°C (4-59°F)
Indoor Unit Connectable	Total Capacity		50-130 % of outdoor unit capacity			50-130 % of outdoor unit capacity			50-130 % of outdoor unit capacity		
	Model / Quantity	City Multi ^{#1} Branch Box ^{#1}	10 - 140 / 9 15 - 100 / 8	10 - 140 / 10 15 - 100 / 8	10 - 140 / 12 15 - 100 / 8	10 - 140 / 9 15 - 100 / 8	10 - 140 / 10 15 - 100 / 8	10 - 140 / 12 15 - 100 / 8	10 - 200 / 12 15 - 100 / 8	10 - 250 / 30 15 - 50 / 12	10 - 250 / 30 15 - 50 / 12
	Mixed System	Branch Box 1 unit Branch Box 2 units Branch Box 3 units	City Multi Branch Box ^{#1} City Multi Branch Box ^{#1} City Multi Branch Box ^{#1}	10 - 140 / 5 15 - 100 / 5 10 - 140 / 3 or 2 ^{#3} 15 - 100 / 8	10 - 140 / 5 15 - 100 / 5 10 - 140 / 3 15 - 100 / 8	10 - 140 / 5 15 - 100 / 5 10 - 140 / 3 15 - 100 / 8	10 - 140 / 5 15 - 100 / 5 10 - 140 / 3 or 2 ^{#3} 15 - 100 / 8	10 - 140 / 5 15 - 100 / 5 10 - 140 / 3 15 - 100 / 8	10 - 140 / 5 15 - 100 / 5 10 - 200 / 3 15 - 100 / 8	10 - 200 / 5 15 - 100 / 5 10 - 250 / 23 15 - 50 / 10	10 - 250 / 25 15 - 100 / 5 10 - 250 / 23 15 - 50 / 10
Sound Pressure Level (Measured In Anechoic Room)	dB <A>	49/51	50/52	51/53	49/51	50/52	51/53	57/61	55/61	57/62	
Sound Power Level (Measured In Anechoic Room)	dB <A>	69/71	70/72	71/73	69/71	70/72	71/73	76/80	73/79	75/79	
Refrigerant Piping Diameter	Liquid Pipe	mm (in.)	9.52 (3/8)	9.52 (3/8)	9.52 (3/8)	9.52 (3/8)	9.52 (3/8)	9.52 (3/8) ^{#7}	9.52 (3/8) ^{#8}	12.7 (1/2)	
	Gas Pipe	mm (in.)	15.88 (5/8)	15.88 (5/8)	15.88 (5/8)	15.88 (5/8)	15.88 (5/8)	15.88 (5/8)	15.88 (5/8)	22.4 (7/8)	
Fan	Type x Quantity	Propeller Fan x 2	Propeller Fan x 2	Propeller Fan x 2	Propeller Fan x 2	Propeller Fan x 2	Propeller Fan x 2	Propeller Fan x 2	Propeller Fan x 2	Propeller Fan x 2	
	Air Flow Rate	m ³ /min	110	110	110	110	110	134/135.9	165/183	165/183	
		L/s cfm	1,833 3,884	1,833 3,884	1,833 3,884	1,833 3,884	1,833 3,884	1,833 3,884	2,234.8/2,265.5 4,732.2/4,799.3	2,750/3,050 5,826/6,462	2,750/3,050 5,826/6,462
Compressor	Motor Output	kW	0.074 x 2	0.074 x 2	0.074 x 2	0.074 x 2	0.074 x 2	0.074 x 2	0.20 x 2	0.375 x 2	
	Type x Quantity	Scroll hermetic compressor x 1									
External Dimension H*W*D	Starting Method	Inverter									
	Motor Output	kW	2.9	3.5	3.9	2.9	3.5	3.9	5.3	8.87	
Net Weight	mm	1,338 x 1,050 x 330 (+40)						1,662 x 1,050 x 460 (+45)		1,662 x 1,050 x 460 (+45)	
	in.	52-11/16 x 41-11/32 x 13 (+1-9/16)						65-7/16 x 41-11/32 x 187/64 (+1-9/16)		65-7/16 x 41-11/32 x 187/64 (+1-9/16)	

*1,*4 Nominal conditions

	Indoor	Outdoor	Piping Length	Level Difference
Cooling	27°C DB / 19°C WB	35°C	7.5m	0m
Heating	20°C DB	7°C DB / 6°C WB	7.5m	0m

*2 10 to 52°C D.B.: When connecting PKFY-P10/15/20/25/32VLM, PKFY-P15/20/25VBM, PFFY-P20/25/32VCM and PFFY-P20/25/32VCM, PFFY-P20/25/32VLE(R/M), PEFY-PVMA3, M, S and P series indoor unit.

*3 When connecting 7 indoor units via branch box, connectable City Multi indoor units are 3; connecting 8 indoor units via branch box, connectable indoor units are 2.

*5 It is possible to connect 1 Fresh Air type indoor unit to 1 outdoor unit. (1:1 system)

*6 At least 2 indoor units must be connected when using branch box.

*7 Liquid pipe diameter: 12.7mm when piping length is more than 60m.

*8 Liquid pipe diameter: 12.7mm, when further piping length is longer than 90m, and when PEFY-P200 or P250 is connected.

Type	Branch Box	
Model Name	PAC-MK54BC	PAC-MK34BC
Connectable Number of Indoor Units	Maximum 5	Maximum 3
Power Supply (from outdoor unit)	~ / N, 220 / 230 / 240 V, 50 Hz, ~ / N, 220 / 230 V, 60 Hz	
Input	kW	
Running Current	A	
Dimensions	H*W*D	
Weight	kg	
Piping Connection (Flare)	Branch (Indoor Side)	Liquid Gas
	Main (Outdoor Side)	Liquid Gas

* The piping connection size differs according to the type and capacity of outdoor/indoor units. Match the piping connection size of branch box with outdoor/indoor unit. If the piping connection size of branch box does not match the piping connection size of outdoor/indoor unit, use optional different-diameter (deformed) joints to the branch box side. (Connect deformed joint directly to the branch box side.)

PUMY-SM SERIES



R32

PUMY-SM112/125/140VKM
PUMY-SM112/125/140YKM

Air conditioning system supports replacement work by simplifying the installation process. Ideal for supporting renewal needs at small offices and stores, home offices, etc.

System of R32 PUMY

Branch box system

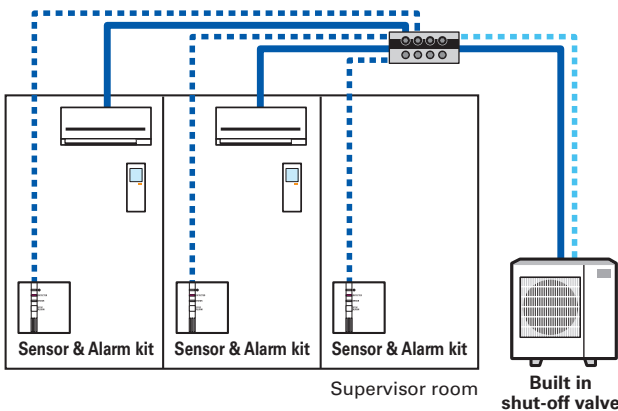

Free plan system

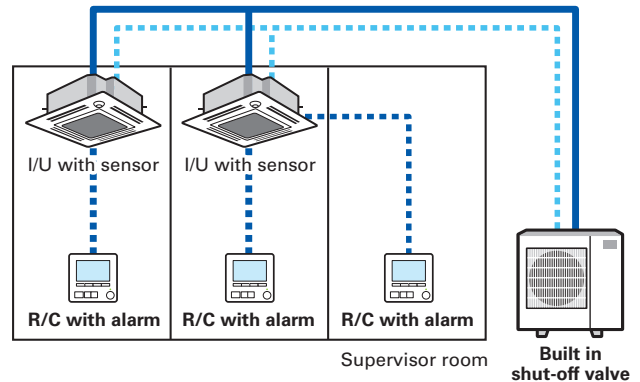

* Solid lines are refrigerant piping. Dotted lines are communication lines.

Summary of System Component

S&A kit • Remote controller

	Appearance	System	Features
S&A kit		PAC-SL72SA-E • Branch box	<ul style="list-style-type: none"> Connected from branch box Sensor and alarm in the device Have 3 types of LED (operation, detection, error) Detection of refrigerant leakage, a kit alerts and LED flashes in red Alarm can be stopped only by a kit in a room that refrigerant leakage occurred
Remote controller		PAR-42MAAB • Free Plan	<ul style="list-style-type: none"> Connected from indoor unit Alarm in the device Have a display In case of refrigerant leakage, R/C alerts and error code and address of indoor unit is shown Alarm can be stopped by a R/C in a room that refrigerant leakage occurred and a supervisor room

* Can be used as a Wired remote control in a Branch box system. However, in this case, a separate S/A kit connection is required.

Branch box

Model name	PAC-MMK40BC(B)	PAC-MMK60BC	
Number of ports	4 ports	6 ports	
Refrigerant	R32	R32	
Input(kW)	0.003	0.006	
Running current(A)	0.15	0.30	
Size(mm)	H	170	Branch Piping(g) liquid/gas [mm] 1st 6.35/9.52 2nd 6.35/9.52 3rd 6.35/12.7 4th 6.35/9.52 5th 6.35/9.52 6th 9.52/15.88
	W	450	
	D	372	
Installation	Ceiling-suspended	✓	Piping/Wiring • Piping connection from both side and wiring connection from one side. • If necessary, you need to flip over only electrical box to connect from the other side. • Possible to make piping connection from both side. • Flipping over only electrical box is not difficult for installer. • 9.52/15.88 can be connected to a large indoor unit placed in a living room or other large room.
	Floor-standing	✓	
	Vertical	✓	
	No need drainpan	✓	
Connection	Flare connection	✓	Instability • 9.52/15.88 can be connected to a large indoor unit placed in a living room or other large room.
	Blazing	✓	

Energy Efficiency

Even with its compact size and light-weight, it has a high EER and COP. Costs are reduced with the energy saving abilities.

* Temperature conditions
EER : Indoor 27°C DB / Outdoor 35°C DB
COP : Indoor 20°C DB / Outdoor 7°C DB
SCOP/SEER: Based on ErP Lot 21/6 calculation method to EN14825.

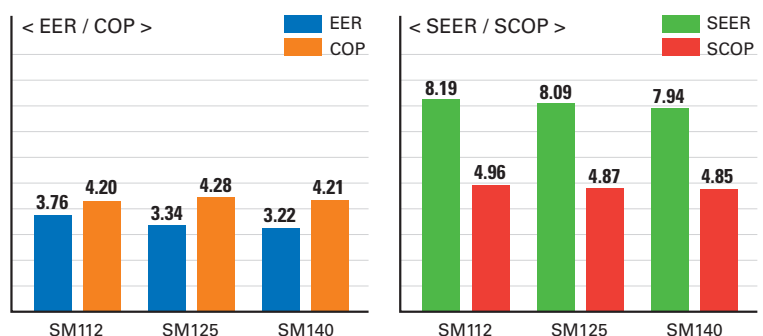

Super Silent Mode*

- Noise level can be reduced up to 10dB(A).
- This allows you to operate the unit even in the night in a residential zone.

* Capacity reduction differs by mode setting.
* PAC-SC36NA-E is required to activate Super Silent mode.
* Cooling mode only.

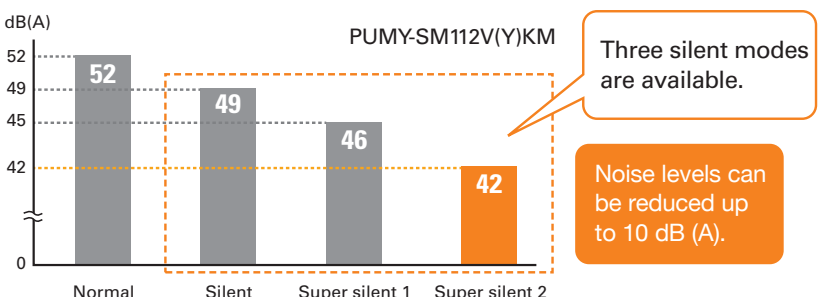

PUMY-SM SERIES
INVERTER MULTI



Model		PUMY-SM112VKM	PUMY-SM125VKM	PUMY-SM140VKM	PUMY-SM112YKM	PUMY-SM125YKM	PUMY-SM140YKM	
Power source		1-phase 220-230-240V 50Hz, 220V 60Hz			3-phase 380-400-415V 50Hz, 380V 60Hz			
Cooling Capacity (Nominal)	Power Input	kW 12.5	14.0	15.5	12.5	14.0	15.5	
	Current Input	kW 3.32	4.19	4.81	3.32	4.19	4.81	
	EER	A 15.40 - 14.73 - 14.12 / 15.40	19.43 - 18.59 - 17.81 / 19.43	22.45 - 21.47 - 20.58 / 22.45	5.31 - 5.04 - 4.86 / 5.31	6.70 - 6.37 - 6.14 / 6.70	7.74 - 7.35 - 7.09 / 7.74	
Temp. Range of Cooling	Indoor Temp.*1	W.B. 15.0-24.0°C (59-75°F)	15.0-24.0°C (59-75°F)	15.0-24.0°C (59-75°F)	15.0-24.0°C (59-75°F)	15.0-24.0°C (59-75°F)	15.0-24.0°C (59-75°F)	
	Outdoor Temp.**2*3	D.B. -5.0-52.0°C (23-126°F)	-5.0-52.0°C (23-126°F)	-5.0-52.0°C (23-126°F)	-5.0-52.0°C (23-126°F)	-5.0-52.0°C (23-126°F)	-5.0-52.0°C (23-126°F)	
Heating Capacity (Nominal)	Power Input	kW 14.0	16.0	17.5	14.0	16.0	17.5	
	Current Input	kW 3.33	3.74	4.16	3.33	3.74	4.16	
	COP	A 15.45 - 14.77 - 14.16 / 15.45	17.30 - 16.55 - 15.86 / 17.30	19.25 - 18.41 - 17.64 / 19.25	5.33 - 5.06 - 4.88 / 5.33	5.97 - 5.67 - 5.46 / 5.97	6.64 - 6.31 - 6.08 / 6.64	
Temp. Range Of Heating	Indoor Temp.	D.B. 15.0-27.0°C (59-81°F)	15.0-27.0°C (59-81°F)	15.0-27.0°C (59-81°F)	15.0-27.0°C (59-81°F)	15.0-27.0°C (59-81°F)	15.0-27.0°C (59-81°F)	
	Outdoor Temp.	W.B. -20.0-15.0°C (-4-59°F)	-20.0-15.0°C (-4-59°F)	-20.0-15.0°C (-4-59°F)	-20.0-15.0°C (-4-59°F)	-20.0-15.0°C (-4-59°F)	-20.0-15.0°C (-4-59°F)	
Indoor Unit Connectable	Total Capacity	50-130 % of outdoor unit capacity						
	Model / Quantity	50-130 % of outdoor unit capacity						
Sound Pressure Level (Cooling/Heating)	City Multi	10-140/12	10-140/12	10-140/12	10-140/12	10-140/12	10-140/12	
	Branch Box	15-100/8	15-100/8	15-100/8	15-100/8	15-100/8	15-100/8	
	Branch box 1unit	10-140/3 or 5**4	10-140/3 or 5**4	10-140/3 or 5**4	10-140/3 or 5**4	10-140/3 or 5**4	10-140/3 or 5**4	
	Branch Box	15-100/4 or 6**5	15-100/4 or 6**5	15-100/4 or 6**5	15-100/4 or 6**5	15-100/4 or 6**5	15-100/4 or 6**5	
	City Multi	10-140/2 or 3**6	10-140/2 or 3**6	10-140/2 or 3**6	10-140/2 or 3**6	10-140/2 or 3**6	10-140/2 or 3**6	
	Branch box 2unit	15-100/8	15-100/8	15-100/8	15-100/8	15-100/8	15-100/8	
	Branch Box	15-100/8	15-100/8	15-100/8	15-100/8	15-100/8	15-100/8	
	Branch Box	15-100/8	15-100/8	15-100/8	15-100/8	15-100/8	15-100/8	
Sound Power Level (Cooling/Heating)		52/54	53/56	54/56	52/54	53/56	54/56	
Refrigerant Piping Diameter	Liquid Pipe	9.52 Flare	9.52 Flare	9.52 Flare	9.52 Flare	9.52 Flare	9.52 Flare	
	Gas Pipe	15.88 Flare	15.88 Flare	15.88 Flare	15.88 Flare	15.88 Flare	15.88 Flare	
Fan	Type x Quantity	Propeller Fan x 1						
	Air Flow Rate	m ³ /min 77						
		L/s 1,283						
		cfm 2,719						
	Motor Output	kW 0.20 x 1						
Compressor	External Static Press.	0Pa / 30Pa**7						
	Type x Quantity	Twin rotary hermetic compressor x 1						
	Starting Method	Inverter						
External Dimension H*W*D	Motor Output	kW 2.3						
		2.6						
Net Weight		3.0						
		3.0						
Pre-Charged Quantity	Weight	kg 3.0						
	CO ₂ equivalent	t 2.03						
Max System Quantity	Weight	kg 7.5						
	CO ₂ equivalent	t 5.06						

*1 15 to 23°C when using branch box(M/S/P series)
 *2 10 to 52°C: incase of connecting PKFYMS*VKM, PKFYMS*VLM indoor unit and M series, S series and P series type indoor unit with branch box.
 *3 -15 to 52°C: when using an optional air protect guide (PAC-SH95AG-E). However, this condition does not apply to the indoor unit listed in*1.
 *4 When connected branch box is PAC-MMK60BC, connectable City Multi indoor units are 3; connected branch box is PAC-MMK40BC(B), connectable City Multi indoor units are 5.
 *5 When connected branch box is PAC-MMK40BC(B), connectable indoor units via branch box are 4; connected branch box is PAC-MMK60BC, connectable indoor units via branch box are 6.
 *6 When connected branch boxes are PAC-MMK40BC(B) and PAC-MMK60BC, connectable City Multi indoor units are 2; connected branch boxes are PAC-MMK40BC(B) and PAC-MMK40BC(B), connectable City Multi indoor units are 3; connected branch boxes are PAC-MMK60BC and PAC-MMK60BC are not allowed.
 *7 0 Pa as initial setting
 *8 96 (212), for PUMY-SM112/125/140VKM-BS
 *9 98 (216), for PUMY-SM112/125/140YKM-BS

Indoor unit connectable table

Model	PUMY-SM112V(Y)KM	PUMY-SM125V(Y)KM	PUMY-SM140V(Y)KM
CM Indoor Only	12	12	12
Branch Box Only	8	8	8
Mix System	3	3	3
Branch Box 1unit	6	6	6
PAC-MMK60BC	9	9	9
Mix System	5	5	5
Branch Box 2unit	4	4	4
PAC-MMK40BC(B)	9	9	9
Mix System	2	2	2
Branch Box 2unit	8	8	8
PAC-MMK60BC + PAC-MMK40BC(B)	10	10	10
Mix System	3	3	3
Branch Box 2unit	8	8	8
PAC-MMK40BC(B) 2unit	11	11	11

			Maximum Meters			
			Only City Multi**1 Indoor Unit	Only Branch Box Connection	Mixed System (City Multi**1 Indoor Unit + Branch Box)	
					City Multi**1 Indoor Unit	Via Branch Box
SM112/ 125/ 140	Refrigerant Piping Length	Total Length	120	120	120	
		Maximum Allowable Length	70	80	70	80
		Farthest Indoor From First Branch	50	-	50	-
		Piping Length Between Outdoor Unit and Branch Boxes	-	55	-	55
	Vertical Differentials Between Units	Indoor/Outdoor (Outdoor higher)	50	40	50	
Indoor/Outdoor (Outdoor Lower)		40	40	40		
	Indoor/Indoor	15	12	12		

PUMY-M SERIES

Air conditioning system supports replacement work by simplifying the installation process. Ideal for supporting renewal needs at small offices and stores, home offices, etc.



R32

PUMY-M200YKM

System of R32 PUMY

Branch box system

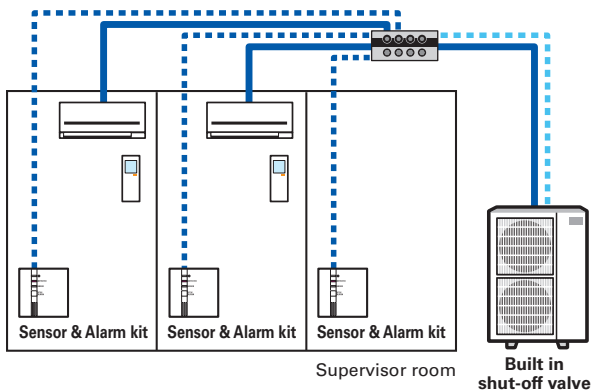

Free plan system

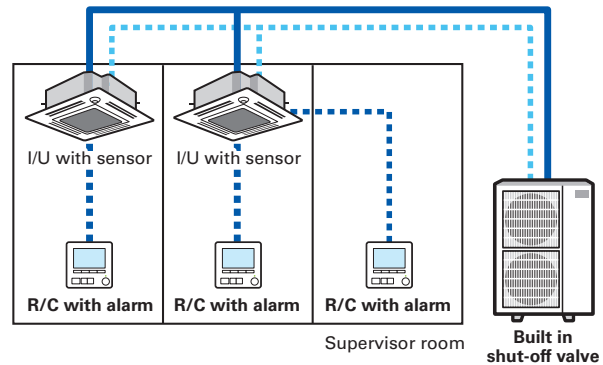

* Solid lines are refrigerant piping. Dotted lines are communication lines.

Summary of System Component

S&A kit • Remote controller

	Appearance	System	Features
S&A kit		• Branch box	<ul style="list-style-type: none"> Connected from branch box Sensor and alarm in the device Have 3 types of LED (operation, detection, error) Detection of refrigerant leakage, a kit alerts and LED flashes in red Alarm can be stopped only by a kit in a room that refrigerant leakage occurred
Remote controller		• Free Plan	<ul style="list-style-type: none"> Connected from indoor unit Alarm in the device Have a display In case of refrigerant leakage, R/C alerts and error code and address of indoor unit is shown Alarm can be stopped by a R/C in a room that refrigerant leakage occurred and a supervisor room

* Can be used as a Wired remote control in a Branch box system. However, in this case, a separate S/A kit connection is required.

Branch box

Model name	PAC-MMK40BC(B)	PAC-MMK60BC
Number of ports	4 ports	6 ports
Refrigerant	R32	R32
Input(kW)	0.003	0.006
Running current(A)	0.15	0.30
Size(mm)		
H	170	170
W	450	665
D	372	420
Installation		
Ceiling-suspended	✓	✓
Floor-standing	✓	✓
Vertical	✓	✓
No need drainpan	✓	✓
Connection		
Flare connection	✓	✓
Blazing	✓	—

Branch Piping(φ) liquid/gas [mm]	1st	6.35/9.52
	2nd	6.35/9.52
	3rd	6.35/12.7
	4th	6.35/9.52
	5th	6.35/9.52
	6th	9.52/15.88
Piping/Wiring		<ul style="list-style-type: none"> Piping connection from both side and wiring connection from one side. If necessary, you need to flip over only electrical box to connect from the other side.
	Instability	<ul style="list-style-type: none"> Possible to make piping connection from both side. Flipping over only electrical box is not difficult for installer. φ9.52/φ15.88 can be connected to a large indoor unit placed in a living room or other large room.

System of R32 PUMY Comply with EN378

Branch box system

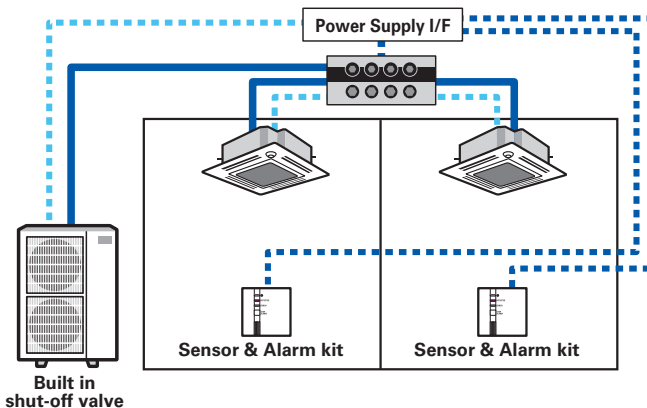

Summary of System Component

S&A kit • Remote controller

	Appearance	System	Features
S&A kit		• Branch box	<ul style="list-style-type: none"> Connected from Power supply interface Sensor and alarm in the device Have 3 types of LED (operation, detection, error) Detection of refrigerant leakage, a kit alerts and LED flashes in red Alarm can be stopped only by a kit in a room that refrigerant leakage occurred
Power Supply Interface		• Branch box	<ul style="list-style-type: none"> Independent power supply to S&A kit Detection of refrigerant leakage and error in S&A kit, an IF outputs information to an outdoor unit and a branch box PCB board and a box for protection

Branch box

Model name	PAC-MMK40BC(B)	PAC-MMK60BC
Number of ports	4 ports	6 ports
Refrigerant	R32	R32
Input(kW)	0.003	0.006
Running current(A)	0.15	0.30
Size(mm)		
H	170	170
W	450	665
D	372	420
Installation		
Ceiling-suspended	✓	✓
Floor-standing	✓	✓
Vertical	✓	✓
No need drainpan	✓	✓
Connection		
Flare connection	✓	✓
Blazing	✓	—

Branch Piping(φ) liquid/gas [mm]	1st	6.35/9.52
	2nd	6.35/9.52
	3rd	6.35/12.7
	4th	6.35/9.52
	5th	6.35/9.52
	6th	9.52/15.88
Piping/Wiring		<ul style="list-style-type: none"> Piping connection from both side and wiring connection from one side. If necessary, you need to flip over only electrical box to connect from the other side.
	Instability	<ul style="list-style-type: none"> Possible to make piping connection from both side. Flipping over only electrical box is not difficult for installer. φ9.52/φ15.88 can be connected to a large indoor unit placed in a living room or other large room.

Energy Efficiency

Costs are reduced with the energy saving abilities.

* Temperature conditions
 EER : Indoor 27°C DB / Outdoor 35°C DB
 COP : Indoor 20°C DB / Outdoor 7°C DB
 SCOP/SEER: Based on ErP Lot 21/6 calculation method to EN14825.

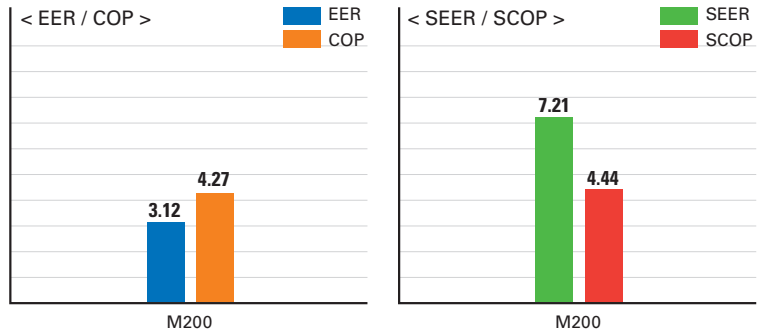

PUMY-M SERIES

INVERTER MULTI



Model		PUMY-M200YKM (-BS)		
Power source		3-phase 380-400-415V 50Hz		
Cooling Capacity*1 (Nominal)		22.4		
	Power Input	kW		
	Current Input	A		
Temp. Range of Cooling	EER	11.99 - 11.39 - 10.98		
	Indoor Temp.*2	W.B.		
	Outdoor Temp.*3	D.B.		
Heating Capacity*4 (Nominal)		25.0		
	Power Input	kW		
	Current Input	A		
	COP	9.77 - 9.30 - 8.95		
Temp. Range Of Heating	COP	4.27		
	Indoor Temp.*5	D.B.		
	Outdoor Temp.	W.B.		
Indoor Unit Connectable	Total Capacity		50~130 % of outdoor unit capacity	
	Model / Quantity		10 - 140 / 12	
	Mixed System	Branch box 1unit	City Multi	15 - 100 / 8
		Branch box 2unit	City Multi	10 - 140 / 3 or 5
	Branch box 1unit	Branch box	City Multi	15 - 100 / 4 or 6
		Branch box	City Multi	10 - 140 / 2 or 3
Branch box 2unit	Branch box	City Multi	15 - 100 / 8	
	Branch box	City Multi	15 - 100 / 8	
Sound Pressure Level (Cooling/Heating)		dB <A>		
		56 / 61		
Sound Power Level (Cooling/Heating)		dB <A>		
		74 / 79		
Refrigerant Piping Diameter	Liquid Pipe	mm (in.)		
	Gas Pipe	9.52 (3/8)		
Fan	Type x Quantity	19.05 (4/3)		
	Air Flow Rate	Propeller Fan x 2		
Compressor	Motor Output	m³/min		
		135.9		
		L/s		
		2,265		
External Dimension H*W*D	Motor Output	cfm		
		4,799		
		kW		
		0.20 x 2		
Net Weight	Type x Quantity	Twin rotary hermetic compressor x 1		
	Starting Method	Inverter		
	Motor Output	kW		
		5.0		
Pre-Charged Quantity	Weight	mm		
	CO2 equivalent	1,338 x 1,050 x 330(+40)		
Max System Quantity	Weight	in.		
	CO2 equivalent	52-11/16 x 41-11/32 x 13 (+1-10/16)		
		kg (lbs)		
		128(282) **		
		kg		
		3.0		
		t		
		2.03		
		kg		
		12.4		
		t		
		8.37		

*1,*4 Nominal conditions
 *2 15 to 23°C W.B. [59 to 73°F W.B.] when using branch box (M/S/P series)
 *3 -15 to 52°C D.B. [50 to 126°F D.B.], when using an optional air protect guide [PAC-SH95AG-E]
 10 to 52°C D.B. when the following indoor units are connected: PCFY or M/S/P series type indoor unit
 15 to 52°C D.B. when the following indoor units are connected: PKFY*VLM or PKFY*VKM
 *5 20 to 27°C D.B. [68 to 81°F W.B.] when using branch box (M/S/P series)
 *6 At least two indoor units must be connected when using branch box.
 *7 129 (284), for PUMY-M200YKM-BS

Indoor unit connectable table

Model	PUMY-M200YKM
CM Indoor Only	12
Branch Box Only	8
Mix System	3
Branch Box 1unit	6
PAC-MMK60BC	9
Mix System	5
Branch Box 2unit	4
PAC-MMK40BC(B)	9
Mix System	2
Branch Box 2unit	8
PAC-MMK60BC + PAC-MMK40BC(B)	10
Mix System	3
Branch Box 2unit	8
PAC-MMK40BC(B) 2unit	11

M200	Refrigerant Piping Length	Total Length	Maximum Meters			
			Only City Multi*1 Indoor Unit	Only Branch Box Connection	Mixed System (City Multi*1 Indoor Unit + Branch Box)	
					City Multi*1 Indoor Unit	Via Branch Box
Vertical Differentials Between Units	Indoor/Outdoor (Outdoor higher)	150	150	150		
		80	80	80		
		50	-	50	-	
		-	55	-	55	
Indoor/Outdoor (Outdoor Lower)	50	50	50			
	40	40	40			
Indoor/Indoor	15	12	12			

■ PUMY-SP Series

Branch Box Connection Compatibility Table for PUMY-SP112/125/140

Series	Type	Model Name	Capacity											
			15	18	20	22	25	35	42	50	60	71	100	
M series	Wall-Mounted	MSZ-LN•VG2					●	●		●				
		MSZ-RW•VG-E					●	●		●				
		MSZ-AP•VG(K)	●		●		●	●	●	●				
		MSZ-AY•VG(K)(P)	●		●		●	●	●	●				
		MSZ-FH•VE2					●	●	●	●				
		MSZ-EF•VG(K)		●		●	●	●	●	●				
		MSZ-SF•VA	●		●									
		MSZ-AP•VF-E	●		●									
	MSZ-SF•VE3					●	●	●	●					
	MSZ-GF•VE2										●	●		
	Floor-Standing	MFZ-KT•VG					●	●		●				
		MFZ-KJ•VE-E					●	●		●				
1-way Cassette	MLZ-KP•VF					●	●		●					
	MLZ-KA•VA-E					●	●		●					
S series	Ceiling-Concealed	SEZ-M•DA(L)(2)					●*1	●*1		●*1	●*1	●*1		
		SEZ-KD•VA-E					●*1	●*1		●*1	●*1	●*1		
	2x2 Cassette	●*1				●*1	●*1		●*1					
	SLZ-KF•VA-E					●*1	●*1		●*1					
P series	Ceiling-Suspended	PCA-M•KA(2)						●*1		●*1	●*1	●*1	●*1	
		PCA-RP•KAQ-E						●*1		●*1	●*1	●*1	●*1	
	4-way Cassette	PLA-M•EA(2)						●*1		●*1	●*1	●*1	●*1	
		PLA-RP•EA-E						●*1		●*1	●*1	●*1	●*1	
	Ceiling-Concealed	PEAD-M•JA(L)(2)								●*1	●*1	●*1	●*1	
		PEAD-RP•JAQ(L)-E								●*1	●*1	●*1	●*1	

*1 Some functions that can be used by connecting to the P series outdoor unit cannot be used with the PUMY series.

LEV Kit Connection Compatibility Table for PUMY-SP112/125/140

Series	I/U Type	Model Name	Capacity										
			15	18	20	22	25	35	42	50	60	71	
M series	Wall-Mounted	MSZ-LN•VG2					●	●		●			
		MSZ-AP•VG(K)	●		●		●	●	●	●			
		MSZ-AY•VG(K)(P)	●		●		●	●	●	●			
		MSZ-FH•VE2					●	●	●	●			
		MSZ-EF•VG(K)		●		●	●	●	●	●			
		MSZ-SF•VA	●		●								
		MSZ-AP•VF-E	●		●								
	MSZ-SF•VE3					●	●	●	●				
Floor-Standing	MFZ-KT•VG					●	●		●				

CITY MULTI Indoor Unit Compatibility Table for PUMY-SP112/125/140

Series	Type	Model Name	Capacity														
			P10	P15	P20	P25	P32	P40	P50	P63	P71	P80	P100	P125	P140	P200	
CITY MULTI series	1-way cassette	PMFY-P•VBM-E			●	●	●	●	●	●							
		2-way cassette			●	●	●	●	●	●			●	●			
		4-way cassette	PLFY-M•VEM-E			●	●	●	●	●	●			●	●		
			PLFY-M•VEM6-E			●	●	●	●	●	●	●		●	●		
			PLFY-P•VBM-E					●	●	●	●	●		●	●		
		PLFY-P•VEM-E					●	●	●	●	●		●	●			
		PLFY-P•VCM-E		●	●	●	●	●	●				●	●			
	PLFY-P•VFM-E		●	●	●	●	●	●									
	Ceiling-concealed	PEFY-P•VMR-E-L/R			●	●	●	●	●	●							
		PEFY-P•VMS1(L)-E		●	●	●	●	●	●	●							
		PLFY-P•VMA(L)-E			●	●	●	●	●	●	●		●	●	●		
		PEFY-M•VMA(L)-A(1)			●	●	●	●	●	●	●		●	●	●		
		PEFY-P•VMH(S)-E							●	●	●	●	●	●	●		
		PEFY-P•VMH-E-F										●				●	
		PEFY-P•VMHS-E-F												●			
	Ceiling-suspended	PCFY-P•VKM-E	●					●		●			●	●			
	Wall-mounted	PKFY-P•VLM-E	●	●	●	●	●	●	●								
		PKFY-P•VBM-E		●	●	●											
		PKFY-P•VHM-E					●	●	●								
		PKFY-P•VKM-E								●			●				
Built in	PDFY-P•VM-E			●	●	●	●	●	●	●	●	●	●				
Floor-standing	PFFY-P•VKM-E2			●	●	●	●	●									
	PFFY-P•VLEM-E			●	●	●	●	●	●								
	PFFY-P•VLRM-E			●	●	●	●	●	●	●							
	PFFY-P•VLRMM-E			●	●	●	●	●	●	●							
	PFFY-P•VCM-E			●	●	●	●	●	●	●							
Lossnay *1															GUF-50/100RD(H4)		

*1 Do not connect Lossnay remote controller(s). (PZ-61DR-E, PZ-60DR-E, PZ-52SF-E, PZ-43SMF-E)

PUMY-P Series

Branch Box Connection Compatibility Table for PUMY-P112/125/140/200

Series	Type	Model Name	Capacity												
			15	18	20	22	25	35	42	50	60	71	100		
M series	Wall-Mounted	MSZ-LN•VE2						•							
		MSZ-AP•VG(K)	•					•			•				
		MSZ-AY•VG(K)	•					•			•				
		MSZ-AY•VGKP						•			•				
		MSZ-FH•VE2						•			•				
		MSZ-EF•VE		•				•			•				
		MSZ-EF•VG(K)		•				•			•				
		MSZ-SF•VA	•					•			•				
		MSZ-AP•VF	•					•			•				
		MSZ-SF•VE3						•			•				
		MSZ-GF•VE2											•		•
		MSZ-RW•VG(2)						•*1		•*1		•*1			
		Floor-Standing	MFZ-KT•VG							•		•			
			MFZ-KJ•VE-E							•		•			
1-way Cassette	MLZ-KP•VF							•		•					
	MLZ-KY•VG				•			•		•					
S series	Ceiling-Concealed	SEZ-M•DA(L)						•		•			•		
		SEZ-KD•VA-E						•		•			•		
	SEZ-M•DA3						•		•			•			
	2x2 Cassette	SLZ-M•FA3	•						•		•				
SLZ-KF•VA2								•		•					
P series	Ceiling-Suspended	PCA-M•KA3						•		•			•		
		PCA-RP•KAQ-R2						•		•			•		
	4-way Cassette	PLA-M•EA3							•		•			•	
		PLA-RP•EA-E							•		•			•	
	Ceiling-Concealed	PEAD-M•JA(L)3							•		•			•	
		PEAD-RP•JA(L)Q-E							•		•			•	

LEV Kit Connection Compatibility Table for PUMY-P112/125/140/200

Series	I/U Type	Model Name	Capacity											
			15	18	20	22	25	35	42	50	60	71		
M series	Wall-Mounted	MSZ-LN•VG2						•						
		MSZ-AP•VG(K)	•					•			•			
		MSZ-AY•VG(K)(P)						•			•			
		MSZ-FH•VE2						•			•			
		MSZ-EF•VG(K)		•				•			•			
		MSZ-SF•VA	•					•			•			
		MSZ-SF•VE3						•			•			
		MSZ-EF•VE		•				•			•			
		MSZ-AP•VF	•					•			•			
		MSZ-RW•VG(2)						•*1		•*1		•*1		
		Floor-Standing	MFZ-KT•VG							•		•		
			MFZ-KJ•VE2							•		•		

CITY MULTI Indoor Unit Compatibility Table for PUMY-P112/125/140

Series	Type	Model Name	Capacity														
			P10	P15	P20	P25	P32	P40	P50	P63	P71	P80	P100	P125	P140	P200	
CITY MULTI series	1-way cassette	PMFY-P•VBM-E			•												
		PLFY-P•VLMD-E			•									•			
	2-way cassette	PLFY-P•VMMD-E			•									•			
		PLFY-M•VEM-E			•									•			
	4-way cassette	PLFY-M•VEM6-E			•									•			
		PLFY-P•VFM-E		•										•			
		PLFY-P•VEM-E			•									•			
		PEFY-P•VMR-E-L/R		•										•			
	Ceiling-concealed	PEFY-P•VMS1(L)-E			•									•			
		PEFY-M•VMA(L)-A(1)			•									•			
		PEFY-P•VMHS-E			•									•			
		PEFY-P•VMHS-E-F			•									•			
		PEFY-P•VMA(L)-E/E2			•									•			
		PEFY-P•VMA(L)-E3/E4			•									•			
		Ceiling-suspended	PCFY-P•VKM-E			•									•		
			PKFY-P•VLM-E	•	•												
	Wall-mounted	PKFY-P•VKM-E			•									•			
		PFFY-P•VKM-E2			•									•			
		PFFY-P•VLEM-E			•									•			
		PFFY-P•VLRM-E			•									•			
PFFY-P•VLRMM-E				•									•				
PFFY-P•VCM-E				•									•				
PFFY-P•VEM-E				•									•				
ATW		PWFY-P•VM-E1 *2												•			
Lossnay *3		GUF-50/100RD(H)4															

CITY MULTI Indoor Unit Compatibility Table for PUMY-P200

Series	Type	Model Name	Capacity													
			P10	P15	P20	P25	P32	P40	P50	P63	P71	P80	P100	P125	P140	P200
CITY MULTI series	1-way cassette	PMFY-P•VBM-E			•											
		PLFY-P•VLMD-E			•									•		
	2-way cassette	PLFY-P•VMMD-E			•									•		
		PLFY-M•VEM-E			•									•		
	4-way cassette	PLFY-M•VEM6-E			•									•		
		PLFY-P•VBM-E			•									•		
		PLFY-P•VEM-E			•									•		
		PLFY-P•VFM-E		•										•		
	Ceiling-concealed	PEFY-P•VMR-E-L/R		•										•		
		PEFY-P•VMS1(L)-E			•									•		
		PEFY-M•VMA(L)-A(1)			•									•		
		PEFY-P•VMHS-E			•									•		
		PEFY-P•VMHS-E-F			•									•		
		PEFY-P•VMA(L)-E/E2			•									•		
		PEFY-P•VMA(L)-E3			•									•		
		Ceiling-suspended	PCFY-P•VKM-E			•									•	
	PKFY-P•VLM-E		•	•												
	Wall-mounted	PKFY-P•VKM-E			•									•		
		PFFY-P•VKM-E2			•									•		
		PFFY-P•VLEM-E			•									•		
PFFY-P•VLRM-E				•									•			
PFFY-P•VLRMM-E				•									•			
PFFY-P•VCM-E				•									•			
PFFY-P•VEM-E				•									•			
Lossnay *3			GUF-50/100RD(H)4													

*1 Note that connection is allowed only for PUMY-P200YKM4.

*2 Note that connection is not allowed inside EU countries and UK. PWFY can not connect to PUMY-P200YKM4.

*3 Do not connect Lossnay remote controller(s). (PZ-61DR-E, PZ-60DR-E, PZ-52SF-E, PZ-43SMF-E)

■ PUMY-P Series

Branch Box Connection Compatibility Table for PUMY-P250/300

Series	Type	Model Name	Capacity															
			15	18	20	22	25	35	42	50	60	71	100					
M series	Wall-Mounted	MSZ-LN•VG2						●	●	●	●	●	●	●	●	●	●	
		MSZ-RW•VG(2)						●	●	●	●	●	●	●	●	●	●	
		MSZ-AP•VG(K)	●					●	●	●	●	●	●	●	●	●	●	●
		MSZ-AY•VG(K)(P)	●					●	●	●	●	●	●	●	●	●	●	●
		MSZ-FH•VE2						●	●	●	●	●	●	●	●	●	●	●
		MSZ-EF•VG(K)						●	●	●	●	●	●	●	●	●	●	●
	Floor-Standing	MFZ-KT•VG						●	●	●	●	●	●	●	●	●	●	
	1-way Cassette	MLZ-KY•VG						●	●	●	●	●	●	●	●	●	●	
S series	Ceiling-Concealed	SEZ-M•DA3						●	●	●	●	●	●	●	●	●	●	
	2x2 Cassette	SLZ-M•FA3	●					●	●	●	●	●	●	●	●	●	●	
P series	Ceiling-Suspended	PCA-M•KA3						●	●	●	●	●	●	●	●	●	●	
	4-way Cassette	PLA-M•EA3						●	●	●	●	●	●	●	●	●	●	
	Ceiling-Concealed	PEAD-M•JA(L)3						●	●	●	●	●	●	●	●	●	●	

LEV Kit Connection Compatibility Table for PUMY-P250/300

Series	I/U Type	Model Name	Capacity										
			15	18	20	22	25	35	42	50			
M series	Wall-Mounted	MSZ-LN•VG2						●	●	●	●	●	●
		MSZ-AP•VG(K)	●					●	●	●	●	●	●
		MSZ-AY•VG(K)(P)	●					●	●	●	●	●	●
		MSZ-FH•VE2						●	●	●	●	●	●
		MSZ-EF•VG(K)						●	●	●	●	●	●
		MSZ-EF•VE						●	●	●	●	●	●
		MSZ-SF•VA	●					●	●	●	●	●	●
		MSZ-SF•VE3						●	●	●	●	●	●
		MSZ-AP•VF	●					●	●	●	●	●	●
			Floor-Standing	MFZ-KT•VG						●	●	●	●

CITY MULTI Indoor Unit Compatibility Table for PUMY-P250/300

Series	Type	Model Name	Capacity															
			P10	P15	P20	P25	P32	P40	P50	P63	P71	P80	P100	P125	P140	P200	P250	
CITY MULTI series	1-way cassette	PMFY-P•VBM-E																
		PLFY-P•VLM-D-E			●	●	●	●	●	●	●	●	●	●	●	●	●	●
		PLFY-P•VMM-D-E			●	●	●	●	●	●	●	●	●	●	●	●	●	●
	4-way cassette	PLFY-M•VEM-E			●	●	●	●	●	●	●	●	●	●	●	●	●	●
		PLFY-M•VEM6-E			●	●	●	●	●	●	●	●	●	●	●	●	●	●
		PLFY-P•VFM-E		●	●	●	●	●	●	●	●	●	●	●	●	●	●	●
		PLFY-P•VEM-E			●	●	●	●	●	●	●	●	●	●	●	●	●	●
		PEFY-P•VMR-E-L/R			●	●	●	●	●	●	●	●	●	●	●	●	●	●
	Ceiling-concealed	PEFY-P•VMS1(L)-E		●	●	●	●	●	●	●	●	●	●	●	●	●	●	●
		PEFY-M•VMA(L)-A(1)			●	●	●	●	●	●	●	●	●	●	●	●	●	●
		PEFY-P•VMA(L)-A1			●	●	●	●	●	●	●	●	●	●	●	●	●	●
		PEFY-P•VMHS-E			●	●	●	●	●	●	●	●	●	●	●	●	●	●
		PEFY-P•VMHS-E-F			●	●	●	●	●	●	●	●	●	●	●	●	●	●
		PEFY-P•VMA(L)-E/E2			●	●	●	●	●	●	●	●	●	●	●	●	●	●
		PEFY-P•VMA(L)-E3/E4			●	●	●	●	●	●	●	●	●	●	●	●	●	●
		PCFY-P•VKM-E			●	●	●	●	●	●	●	●	●	●	●	●	●	●
	Wall-mounted	PKFY-P•VLM-E	●	●	●	●	●	●	●	●	●	●	●	●	●	●	●	●
		PKFY-P•VKM-E			●	●	●	●	●	●	●	●	●	●	●	●	●	●
	Floor-standing	PFY-P•VKM-E2			●	●	●	●	●	●	●	●	●	●	●	●	●	●
PFY-P•VLEM-E				●	●	●	●	●	●	●	●	●	●	●	●	●	●	
PFY-P•VCM-E				●	●	●	●	●	●	●	●	●	●	●	●	●	●	
PFY-P•VEM-E				●	●	●	●	●	●	●	●	●	●	●	●	●	●	
Lossnay *1																	GUF-50/100RD(H)4	

*1 Do not connect Lossnay remote controller(s). (PZ-61DR-E, PZ-60DR-E, PZ-52SF-E, PZ-43SMF-E)

■ PUMY-SM Series

Branch Box Connection Compatibility Table for PUMY-SM112/125/140

Model Name	15	18	20	22	25	35	42	50	60	71	100
M series	MSZ-RW•VG							●	●	●	●
	MSZ-LN•VG2							●	●	●	●
	MSZ-AP•VG(K)	●						●	●	●	●
	MSZ-AY•VG(K)(P)	●						●	●	●	●
	MSZ-EF•VG(K)								●	●	●
	MSZ-BT•VG(K)								●	●	●
	MLZ-KY•VG								●	●	●
	MLZ-KP•VF								●	●	●
S series	SEZ-M•DA3							●	●	●	●
	SLZ-M•FA3	●						●	●	●	●
P series	PCA-M•KA3							●	●	●	●
	PLA-M•EA3							●	●	●	●
	PEAD-M•JA(L)3							●	●	●	●

■ PUMY-M Series

Branch Box Connection Compatibility Table for PUMY-M200

Model Name	15	18	20	22	25	35	42	50	60	71	100
M series	MSZ-RW•VG							●	●	●	●
	MSZ-LN•VG2							●	●	●	●
	MSZ-AP•VG(K)	●						●	●	●	●
	MSZ-AY•VG(K)(P)	●						●	●	●	●
	MSZ-EF•VG(K)								●	●	●
	MSZ-BT•VG(K)								●	●	●
	MLZ-KY•VG								●	●	●
	MLZ-KP•VF								●	●	●
S series	SEZ-M•DA3							●	●	●	●
	SLZ-M•FA3	●						●	●	●	●
P series	PCA-M•KA3							●	●	●	●
	PLA-M•EA3							●	●	●	●
	PEAD-M•JA(L)3							●	●	●	●

CITY MULTI Indoor Unit Compatibility Table for PUMY-P250/300, PUMY-M200

Model Name	Sensor	10	15	20	25	32	40	50	63	71	80	100	125	140
CITY MULTI series	PLFY-M•VEM6-E							●	●	●	●	●	●	●
	PEFY-M•VMA(L)-A1							●	●	●	●	●	●	●
	PLFY-MS•VEM-E	✓						●	●	●	●	●	●	●
	PLFY-MS•VFM-E	✓						●	●	●	●	●	●	●
	PCFY-MS•VKM-E	✓						●	●	●	●	●	●	●
	PKFY-MS•VLM-E	✓	●					●	●	●	●	●	●	●
	PKFY-MS•VKM-E	✓						●	●	●	●	●	●	●
	PEFY-MS•VMA(L)-A	✓						●	●	●	●	●	●	●

Outdoor Unit Functions

Demand Control

This function reduces the capacity of the outdoor/heat source unit by way of the external input to the outdoor unit. The capacity of the outdoor unit can be reduced in steps, with patterns ranging from 2 to 12 control steps depending on the system. The number of steps that can be set and the corresponding capacity are shown below.

- 2 steps (0-100%)
- 4 steps (0-50-75-100%)
- 8 steps (0-25-38-50-63-75-88-100%)
- 12 steps (0-17-25-34-42-50-59-67-75-84-92-100%)

Possible usage

When power consumption is centrally-controlled within a building, the system can be made to operate in capacity-save mode by receiving external signals.

• System settings example

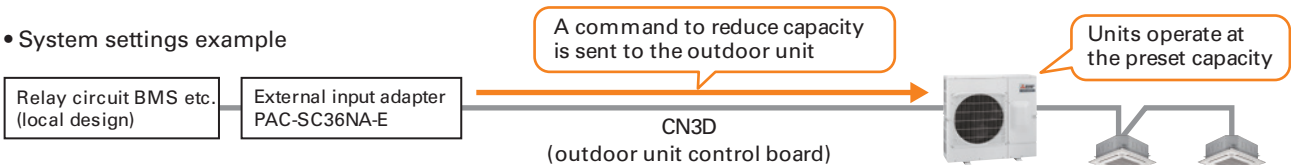

Pump Down Function

This function collects the refrigerant that remains in the indoor unit and the outdoor/heat source unit piping when the refrigerant piping needs to be removed, such as when the air conditioner is relocated.

This function can also be used to stop the operation of the indoor unit and return the refrigerant to the outdoor/heat source unit in the event that a refrigerant leak is detected.

* To detect a refrigerant leak, a circuit that includes a refrigerant leak detection sensor must be designed and prepared on site.

Dual Set Point

Normally, the desired room temperature is set to the same value for cooling and heating. However, the dual set point function allows different temperatures to be set for cooling and heating. When operation switches from cooling to heating or vice versa, the preset temperature changes accordingly.

Setting dual set points in Auto mode on R2 models improves energy efficiency, compared to setting a single set point.

When the operation mode is set to Auto (dual set point) mode, two preset temperatures (one each for cooling and heating) can be set. Depending on the room temperature, the indoor unit will automatically operate in either the cooling or heating mode and keep the room temperature within the preset range.

The outdoor unit does not operate in the comfortable temperature band defined by two temperature points where the thermostat is off. This cuts down on unnecessary operation of the air conditioning system.

* This function is supported only when all the indoor units, remote controllers, and system controllers that are connected to a given group are compatible with the function.

• Operation pattern in Auto (dual set point) mode

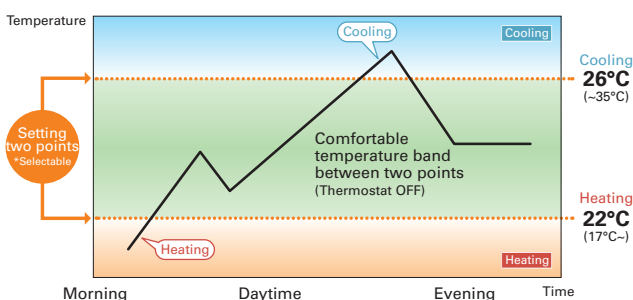

Individual LEV Control

Even if one of the indoor units stops for repair, the LEV of the indoor unit can be closed so that the other indoor units can continue to operate. (No preliminary setting is necessary.)

