

Mitsubishi Lossnay Ventilator

MODEL:

VL-50S2-E (pull cord Type)

VL-50ES2-E (wall switch Type)

Operating Instructions

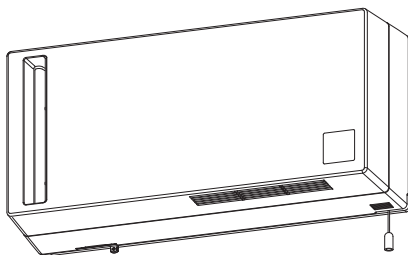
Mitsubishi Lossnay Ventilator
MODELS
VL-50S2-E (pull cord Type)
VL-50ES2-E (wall switch Type)
Operating Instructions
For Customer

Contents	Page
1. Safety precautions	1
2. When using the unit	3
3. Features	4
4. Names of parts	5
5. Before you start the Lossnay	5
6. Operation	6
7. Maintenance	7
8. Troubleshooting	10
9. Specifications	11
10. After-sales servicing	11

Please read these instructions thoroughly to ensure safe and proper use. After reading, store the manual in a handy location for easy access.

Before proceeding with operation, please be sure to read “Safety precautions”, as it will tell you how to operate the Lossnay ventilator properly and safely.

Do not install the unit yourself. (The safety and performance of customer-installed units is not guaranteed.)

If the supply cord is damaged, it must be replaced by the manufacturer, its service agent or a similarly qualified persons in order to avoid a hazard. (VL-50S2-E only)

- Contact your dealer.

1. Safety precautions

Hazards created by mishandling and their severity are indicated by the following markers.

 **Warning:**

This applies to mishandling or misoperation of the product which could lead to a fatal or serious injury.

 **Caution:**

This applies to mishandling or misoperation of the product which will lead to an injury or damage to your home, household effects, etc.

 **Warning**



- Do not cut, damage or physically alter the power cord*1 or subject it to unreasonable bending, pulling, twisting or bundling.

- You could damage the cord, resulting in fire or electric shock.

- Do not turn the Lossnay switch ON or OFF if there is a flammable gas leak.

- Sparks from electric contacts could cause explosions. Open a window to ventilate the room.

Do NOT
disassemble

Do not expose
to water

No wet hands

You must
follow the
instructions
given.

- **Do not use the unit in excessively hot areas (40°C or more), near open flames, areas prone to oily smoke, or where it could come in contact with organic solvents.**
 - Fire could result.
 - **Do not disassemble the unit in ways that require physical alteration or tools.**
 - Fire, electric shock or injury could result.
 - **Do not let the unit get wet.**
 - Fire or electric shock could result.
 - **Do not insert or remove the power plug*¹ with wet hands.**
 - Electric shock could result.
 - **Use at the rated voltage.**
 - Fire or electric shock could result.
 - **Check that there is no dust on the power plug*¹.**
 - A dusty plug could cause fire from a short circuit.
 - **Insert the plug*¹ completely into the socket, making sure it is not loose.**
 - A loose fit could result in electric shock or fire.
 - **Make sure that the outside air intake opening is positioned so that it will not take in combustion gases or other exhaust.**
 - If intake air is not fresh, oxygen could become depleted in the room.
 - **Always shut off circuit breakers or remove the power plug*¹ from the wall outlet during long periods of disuse.**
 - Failure to do so could result in electric shock from deteriorated insulation, or fire from a short circuit.
 - **Install the outdoor weather covers packaged with the unit.**
 - Rainwater entering the unit could result in electric shock, fire or indoor items getting wet.
 - **Immediately halt use in the event of malfunction or breakdown.**
 - Continued use of the Lossnay could result in smoke, fire, electric shock or injury.
- * Promptly shut off the circuit breaker or remove the power plug*¹ from the wall outlet. Then contact the store of

purchase for inspection and repair.
<Examples of malfunction and breakdown>

- Blades do not turn when power is turned on.
- The unit makes strange noises or vibrates while running.
- Blade rotation is slow or irregular. (Motors require periodic maintenance.)
- You smell burning.
- The unit mount is corroded or damaged.

- **Always shut off circuit breakers or remove the power plug*¹ from the wall outlet before performing maintenance work.**
 - Electric shock and burns could result if power is flowing.

Caution

Prohibited

- **Do not place combustion equipment in the direct path of the air from the unit.**
 - Incomplete combustion could result in accidents.
- **If using a step-ladder for maintenance, be sure to place it on level ground where there is nothing underfoot.**
 - Injury could result from falling over.
- **Never attach the unit to the ceiling.**
 - Injury could result if the unit falls.
- **Because this product is designed to be installed at a higher location, install the product at least 1.8 m above the floor.**
 - Failure to heed this warning may result in injury.

Do NOT touch

You must
follow the
instructions
given.

- **A fan rotates inside the unit during operation. Never stick anything inside the unit during operation.**
 - Injury could result.
- **Do not use the unit in a bathroom or other highly humid location.**
 - Electric shock or breakdown could result.
- **Wear gloves when maintaining the unit.**
 - Failure to wear gloves could result in injury.
- **After maintenance, reattach parts securely.**
 - Injury could result if the unit falls.

- **Never remove the power plug*¹ by pulling on the cord. Always grasp the plug itself.**
 - Could result in electric shock or shorts, or could cause fires.
- **If the outside air is cold, winds are strong, snow or rain is falling heavily, or there is mist or fine snow, turn the Lossnay off and close the manual shutter.**
 - Water or snow could infiltrate the Lossnay with the air supply, resulting in weather damage.
- **Other than EU countries:**
This appliance is not intended for use by persons (including children) with reduced physical sensory or mental capabilities, or lack of experience and knowledge, unless they have been given supervision or instruction

concerning use of the appliance by a person responsible for their safety. Children should be supervised to ensure that they do not play with the appliance.

EU countries:

This appliance can be used by children aged from 8 years and above and persons with reduced physical, sensory or mental capabilities or lack of experience and knowledge if they have been given supervision or instruction concerning use of the appliance in a safe way and understand the hazards involved. Children shall not play with the appliance. Cleaning and user maintenance shall not be made by children without supervision.

*¹ Refers only to VL-50S2-E (Lossnay with plug-in power cord).

2. When using the unit

■ **When running in winter, the Lossnay transfers the heat of indoor air to the cold outdoor air as it brings outside air in.**

This means that when outside air is colder than about -10 °C, condensation or frost may form on the panel or inside the unit.

Since condensation and frost formation varies with subtle changes in conditions (indoor humidity, air flow and the like), switch operating modes or temporarily stop the unit as conditions dictate.

When dew condensation has formed on the surface of the unit, wipe it off.

Using the following outside air temperatures as a guide, switch the mode to Exhaust only mode. (Refer to page 6 for details of the mode.)

	Outside air temperature
In operation	-10° C or higher
Exhaust only mode	-10° C to -20° C
Stop	-20° C or lower

■ **Check that the unit is mounted properly before using it.**

- **Is the Lossnay mounted on a wall?**
 - This Lossnay is designed to be mounted only on a wall. If mounted on a ceiling, it may drop off.
- **Is the special outdoor hood mounted on an exterior wall?**

- - Failure to install the hood may allow wind and rain into the unit, damaging it.

■ **Obey the following cautions when using the Lossnay.**

- - **Do not place objects around the unit.**
 - - Such objects may block air outlets or intake openings or may prevent servicing.
 - - They may also prevent you from reaching the wall outlet (for plug-in models).

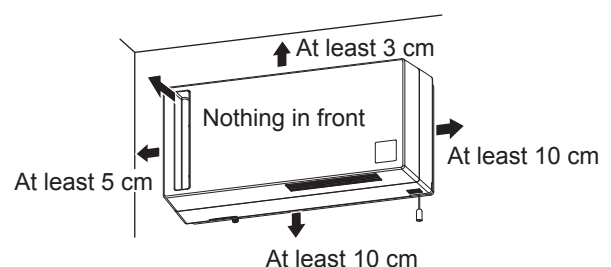

- - **Do not use aerosol sprays (such as insect sprays, hair sprays or cleaners) directly on the unit.**

- - The panel may warp, weaken, or become damaged.

- - **Do not obstruct the panel.**

- - Proper ventilation may be impeded.

- - **Do not pull the cord diagonally (VL-50S2-E only).**

- - The unit will not operate correctly.

- **In the following cases, stop the Lossnay and close its shutter.**
 - If the outside air is cold, winds are strong, snow or rain is falling heavily, there is heavy fog, or fine snow is falling. (Water or snow may infiltrate the Lossnay with the air supply, resulting in weather damage.)
 - During cleaning and inspections (Stop the Lossnay temporarily, resuming operation later.)
- **Do not pull the panel forcefully.**
 - Doing so could cause the product to fall.

- ■ Mitsubishi recommends mounting the Lossnay away from the bed.
 - If the unit is too close, you may hear operating noise or feel cold air blowing while in bed.
- ■ Bugs smaller than the grate openings of the outdoor hood may be able to infiltrate the unit.
- ■ When wind is strong, there may be a rattling sound from the shutter. (This is not a malfunction.)
- ■ The motor and the air filter require periodic maintenance (replacement).
 - Replacement time will vary with frequency of use.



3. Features

The Lossnay ventilator, from Mitsubishi Running the Lossnay

The Lossnay moves dirty indoor air outside (exhausting it) and brings clean air from the outside in (providing air supply). When it supplies air, it brings outside air close to room temperature (functioning as a heat exchanger).

- * The Lossnay is not an air-conditioner. It is a ventilating fan that exchanges heat as it ventilates.
- ◆ Since it not only sends indoor air out but also brings fresh air in, it works well in tightly sealed homes.

- ◆ Since it is a heat exchanger, it provides heating and cooling at a lower cost than ventilators that merely exhaust.
- ◆ Built-in filters reduce the amount of dust, pollen and other particles entering the house in outside air.

1		Exhaust air filter
2		Outside air filter For replacement: P-50F2-E
3		Option High efficiency filter P-50HF2-E

- ◆ To prevent a cold air feeling or dew condensation forming on the unit in winter, Exhaust only mode can be used. (Refer to page 6 for details of the mode.)

4. Names of parts

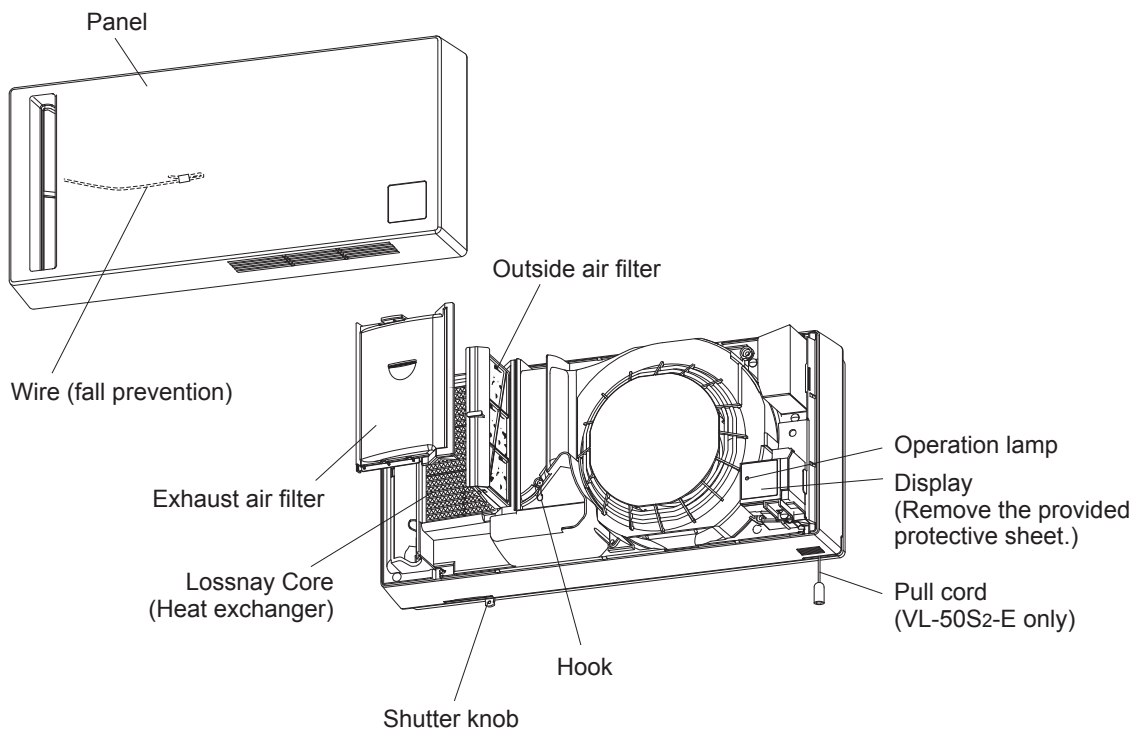

5. Before you start the Lossnay

1. Preparing to turn the power on

1) Turn the circuit breaker on at the distribution board.

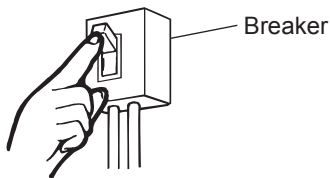

2) Insert the power plug into the wall outlet. (VL-50S2-E only)

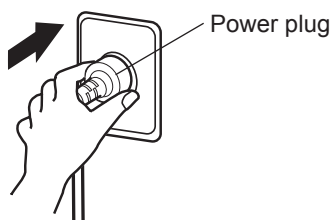

6. Operation

Note

- In the following cases, stop the Lossnay and manually move the shutter knob to the leftmost position (the closed position) to close the shutter.
 - If the outside air is cold, winds are strong, snow or rain is falling heavily, there is heavy fog, or fine snow is falling. (Water or snow may infiltrate the Lossnay with the air supply, resulting in weather damage.)
 - During cleaning and inspections

1. Slide the shutter knob to the open position.

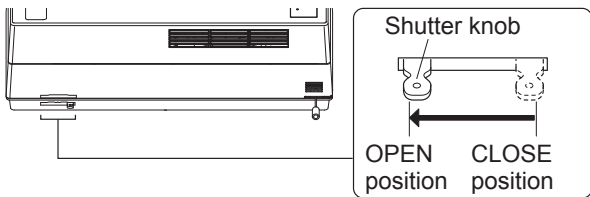

Note

- Make sure that the shutter knob must be located in the open position, and then operate the unit.

2. Operation For VL-50S2-E

Switching operating modes (airflow)
Pull the cord to switch from HI to LO to Off.

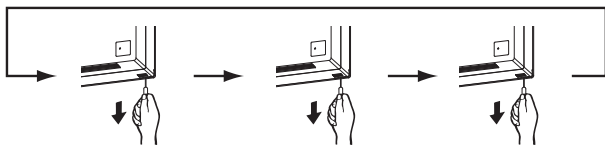

HI operation (Operation indicator lights.) LO operation (Operation indicator goes out.) Off (Operation indicator goes out.)

For VL-50ES2-E

Using the control switches.

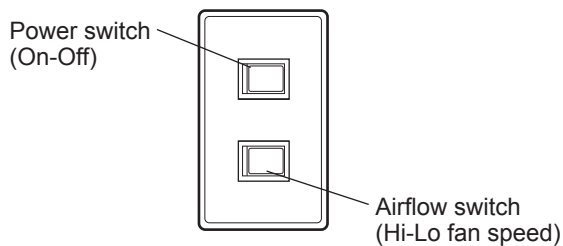

* The switches shown above are only an example. Operations and indicators may vary depending on the switches installed.

3. Operation in Exhaust only mode

What is Exhaust only mode?

When the outside air temperature becomes low in winter and intake air (air supply) feels cold, or there is a concern about dew condensation on the unit, change the mode to Exhaust only mode.

By closing the shutter at the air supply side and half closing the shutter at the exhaust side, operation with suppressed supply air (cold outside air) is performed.

In order to prevent freezing of the heat exchanger, if the outside air temperature becomes -10 °C or lower, make sure to operate in Exhaust only mode.

(*For a guide to outside air temperatures, refer to page 3.)

How to operate Exhaust only mode

Adjust the shutter knob to the Exhaust only position.

- Move the shutter knob to the CLOSE position and then slowly move to the OPEN position and stop at the Exhaust only position.

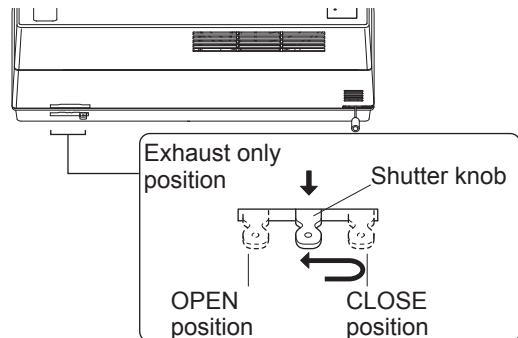

Note

- When Exhaust only mode is no longer necessary, return the shutter knob to the OPEN position.

7. Maintenance

Remove all dust and dirt on air filters and Lossnay cores at regular intervals in order to prevent a deterioration in the Lossnay functions.

Guideline:

Clean the air filters **at least once every six months**.

Clean the Lossnay cores once every two years. (Frequency should be increased depending on the extent of dirt.)

⚠ Warning:

- **Always shut off circuit breakers or, for the VL-50S2-E, remove the power plug from the wall outlet before performing maintenance work.**
- Electric shock and burns could result if power is flowing.

⚠ Caution:

- **Wear gloves when maintaining the unit.**
- Failure to wear gloves could result in injury.
- **If using a step-ladder, be sure to place it on level ground where there is nothing underfoot.**
- Injury could result from falling over.

Removing the parts

(1) Turn the power off

- 1) Turn the Lossnay off.
- 2) Always shut off circuit breakers or, for the VL-50S2-E, remove the power plug from the wall outlet.

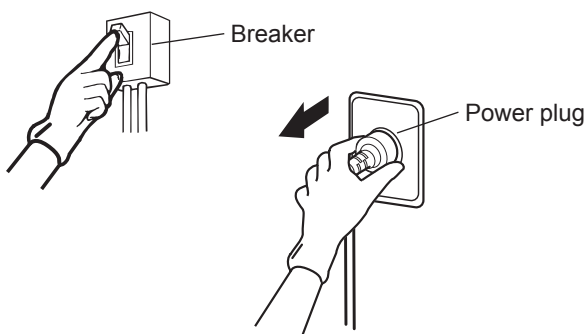

(2) Open the panel.

For horizontal mounting

- 1) As shown in the figure, hold the left and right end of the panel and pull toward you.
- 2) Remove the panel and suspend it.
 - When removing the panel (wire) from the main unit, hold the hook and remove the wire.

- Do not shake the suspended panel. (The wallpaper could be damaged.)

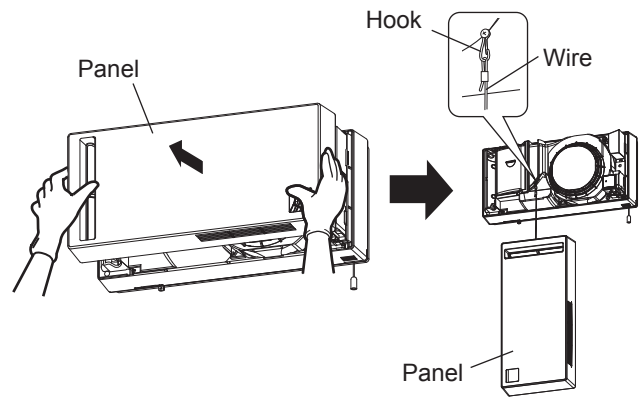

For vertical mounting

- 1) As shown in the figure, hold the top and bottom end of the panel and pull toward you.
- 2) Remove the panel and suspend it.
 - When removing the panel (wire) from the main unit, hold the hook and remove the wire.
 - Do not shake the suspended panel. (The wallpaper could be damaged.)

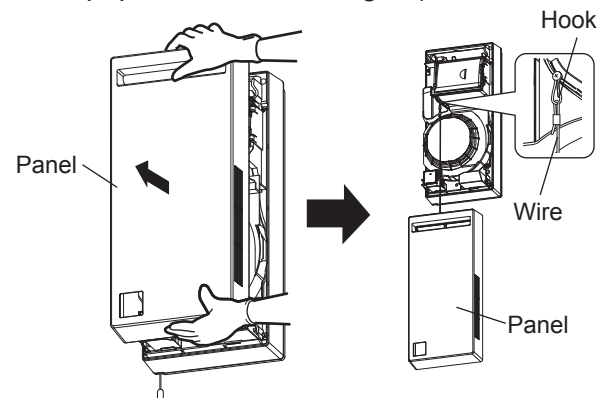

(3) Remove the exhaust air filter.

As shown in the figure, hold the air filter and pull the top of the air filter toward you to detach it from the hooking part on the top to remove it.

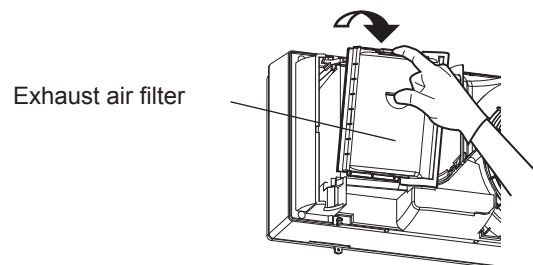

(4) Remove the outside air filter.

Hold the knob of the outside air filter to pull it out.

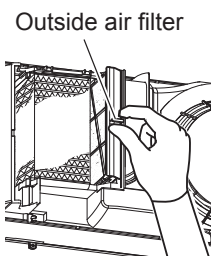

(5) Remove the Lossnay Core.

Press the prong of the Lossnay Core's handle and pull the handle toward you to remove the core.

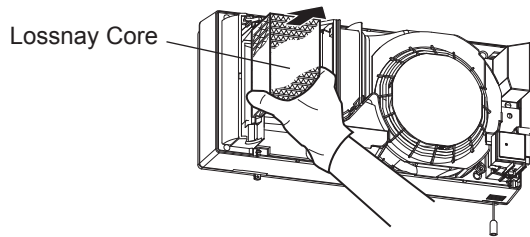

Cleaning

(1) Outside air filter

- 1) Press the tab at two locations to open the filter frame.
- 2) Remove the outside air filter.

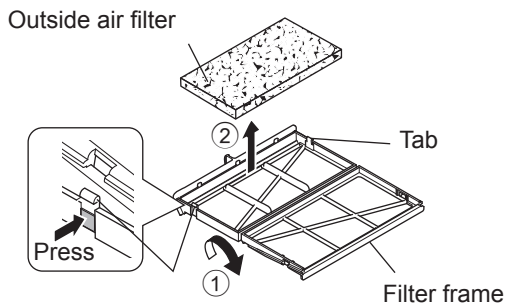

- 3) Remove the dust with a vacuum cleaner.

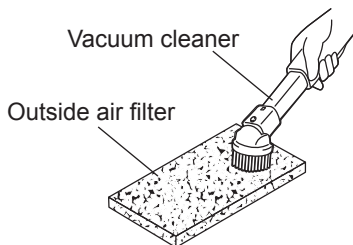

When the filter is heavily soiled, press and wash the filter with cold or warm water (40°C or less), and then air-dry the filter.

Note

- Do not wash the filter as below, otherwise it can be distorted.

- Do not wash the filter with hot water.
- Do not wash the filter by rubbing or scrubbing.
- Do not squeeze or twist the filter.

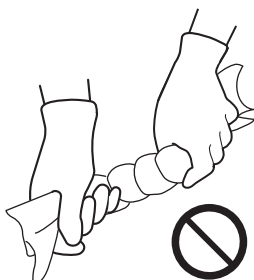

Replacement:

The filter is a consumable part.

We recommend to replace the filter with the replacement filter (P-50F2-E) after you have washed the filter four times.

(2) Exhaust air filter

- 1) Open the exhaust air filter as shown in the figure.
- 2) Either lightly tap with your hand or remove dust with a vacuum cleaner.
- 3) If it is excessively dirty, wipe with a cloth soaked in water and tightly wrung out.

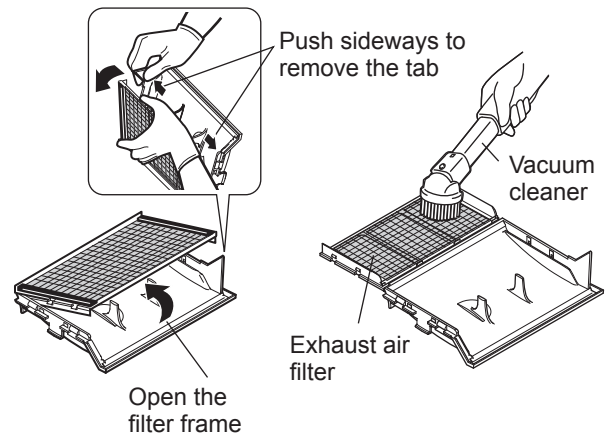

Note

- Never wash with hot water or do rubbing wash.
- Do not dry the filter by directly holding it up to an open flame.
- If a separately available high performance dust filter is used, clean the filter in accordance with the instructions in its Instruction Manual.

(3) Lossnay Core

Use a vacuum cleaner to remove surface dust.

- Vacuum the surface gently with the vacuum cleaner nozzle.

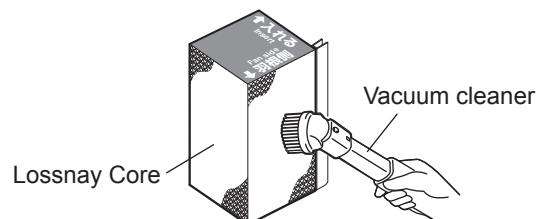

Note

- Do not expose the Lossnay Core to water, chemicals, or volatile solutions.
- Do not wash Lossnay Core with water.
- Do not expose the Lossnay Core close to open flames.
- Do not press wires, screwdrivers or hard vacuum cleaner nozzles into the surface.

Reassembly and checking after maintenance

Mount the filter and Lossnay Core by the opposite of the removal procedure.

⚠ Caution

- After maintenance, reattach parts securely.
- Injury could result if the unit falls.

(1) Mount the Lossnay Core.

- 1) Check the orientation of the "Insert" and "Fan side" markings on Lossnay Core.
- 2) Insert the Lossnay Core guide along the rail of the main unit.
- 3) Push Lossnay Core deeply until the flange and packing of Lossnay Core make contact.

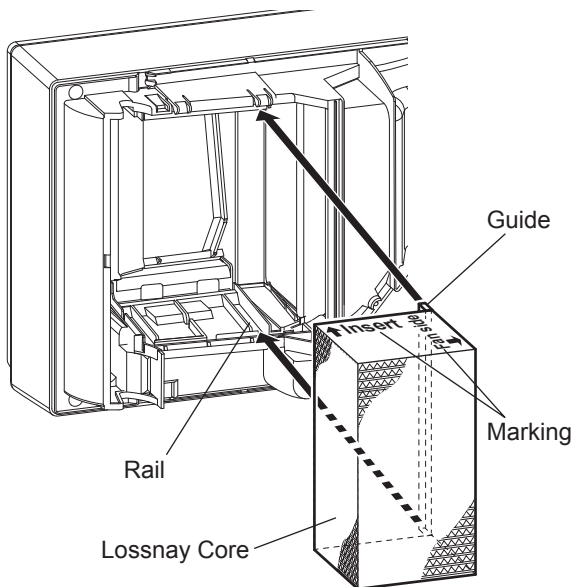

(2) Mount the outside air filter. (See page 9.)

- Place the outside air filter into the filter frame and mount it in the main unit. (Do not confuse the top and bottom.)

(3) Mount the Exhaust air filter

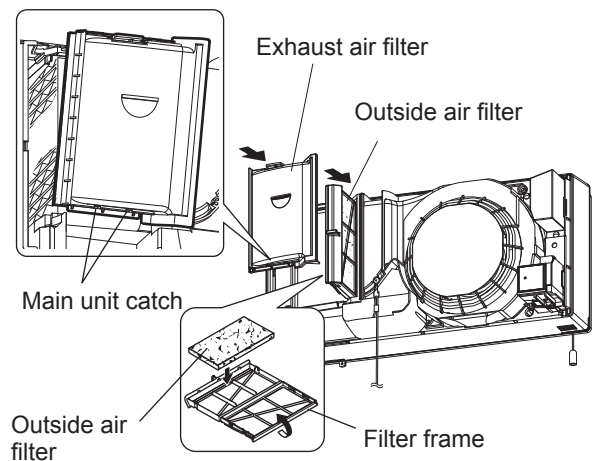

(4) Close the panel.

- Press the panel horizontally against the main unit.

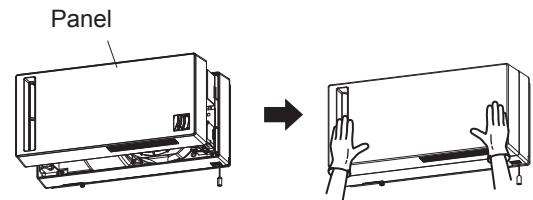

(5) Turn on the circuit breaker or, for the VL-50S2-E, plug the power plug into the wall outlet.

(6) Turn the power on.

(7) After reassembly, check the following.

- Are the filters and the panel attached securely?
- Is the unit making no strange noises?
- Is the unit blowing air? (Be sure to check the unit while it is running. Make sure that the shutter is open.)

Cleaning the panel/main unit

If the panel or main unit becomes dirty, wipe it with a well-wrung cloth soaked in a solution of neutral detergent and lukewarm water (40°C or less), then wipe it with a clean cloth to remove any traces of detergent.

Note

- Use of any of the following solvents in maintenance may warp, weaken or discolor Lossnay components.
 - Paint thinner, alcohol, benzene, gasoline, kerosene, aerosol sprays, alkaline cleaners, chemical wipes, or abrasive-containing detergents, such as cleansers
- Clean any dust off of the plug. (VL-50S2-E only)

8. Troubleshooting

Inspect the unit if any of the following problems occurs. If the problem is not listed below, or the problem persists after inspection, shut off the circuit breaker on the distribution board or, for VL-50S2-E, remove the power plug from the wall outlet, and then contact your dealer.

Model	Problem	Cause	Check the following	Page
VL-50S2-E VL-50ES2-E	Unit does not operate.	No power to main unit.	Check the power plug. (VL-50S2-E only) Check whether a breaker has tripped. Check whether a power failure has occurred.	5
	The unit is louder. The unit is noisy.	The panel or outside air filter is not attached securely.	Reattach the panel or filter.	7
		The outside air filter or exhaust air filter is clogged.	Clean the filter.	7-8
	Less air than normal is coming from the unit.	The outside air filter or exhaust air filter is clogged.	Clean the filter.	7-8
	The operation lamp is not bright.	When the operation mode is changed from HI to LO, the lamp becomes dim.	This is not a malfunction.	—
	Small insects get inside.	Small particles and insects may pass through.	To enhance trapping efficiency, purchase a high performance dust filter.	4
	No air is coming from the unit. Not much air is coming from the unit.	The Lossnay is a heat-exchanging ventilator, so the volume of air will be lower than with an ordinary fan. This is normal.		—
		The shutter is closed.	Open the shutter.	6
	The panel will not close.	The Lossnay Core or outside air filter is not mounted correctly. (A component is out of position or inserted backwards.)	Mounted the component correctly.	7-8
	The incoming air feels cold.	The outside air temperature has dropped.	Turn the unit off temporarily and close the shutter, as dictated by the situation. Operate the unit by setting the shutter position to Exhaust only mode.	5
		Cold air may enter inside if inside the room is in negative pressure for a reason such as that the range hood fan is operating.	This is not a malfunction. Use the unit in Exhaust only mode.	6
	When operating the shutter knob, there is a noise inside.	This sound is the operation sound of the shutter inside the product.	This is not a malfunction.	—
	Cold air or wind comes in more than usual when the unit is stopped.	Is the shutter being kept open?	Move the shutter knob to the CLOSE position.	6
The unit is loud.	The shutter is closed.	Open the shutter.	5	

9. Specifications

Model	Supply voltage (V)	Frequency (Hz)	Notch	Power consumption (W)	Air volume (m ³ /hr)	Temperature exchange efficiency (%)	Noise (dB)	Weight (kg)
VL-50S2-E	220	50	HI	19	51	70	36.5	6.2
			LO	4	15	86	14	
VL-50ES2-E	230	50	HI	20	52.5	69	37	
			LO	4.5	16	85	15	
VL-50ES2-E	240	50	HI	21	54	68	37.5	
			LO	5.0	17	84	15.5	
VL-50ES2-E	220	60	HI	21	54	68	37.5	
			LO	5.5	17	84	15.5	

* Noise values may be higher than those listed depending on the structure of the room.

10. After-sales servicing

Consult with your dealer about the after-sales services provided for this Lossnay product.

- If you hear strange sounds, if no air is blown out or if some other trouble occurs, switch off the power and contact your dealer. Consult with your dealer concerning the cost of inspection or repair work.

■ Retention period of functional repair parts

- We will retain the functional repair parts for six years after terminating production of the product.
- The functional repair part means a part which is necessary to maintain the function of the product.

■ Recommended inspection and maintenance

- After several years of use, the following might occur. We recommend inspection and maintenance by a professional.
- Entry of dust due to deterioration of filters
- Abnormal noise or vibration due to the motor reaching the end of its service life
- Air leakage due to the heat exchanger Lossnay core reaching the end of its service life

The following are consumables:

- Motor
- Supply air filter
- Exhaust air filter
- Lossnay core

■ Repair costs include technical fee, cost of parts, (and business trip charges), etc.

Manufactured by: **MITSUBISHI ELECTRIC CORPORATION**

TOKYO BLDG. 2-7-3, MARUNOUCHI, CHIYODA-KU, TOKYO, 100-8310 JAPAN

Information on Disposal



Note: This symbol mark is for EU countries only.

This symbol mark is according to the directive 2012/19/EU Article 14 Information for users and Annex IX, and/or to the directive 2006/66/EC Article 20 Information for end-users and Annex II.

English

Your MITSUBISHI ELECTRIC product is designed and manufactured with high quality materials and components which can be recycled and/or reused.

This symbol means that electrical and electronic equipment, batteries and accumulators, at their end-of-life, should be disposed of separately from your household waste.

If a chemical symbol is printed beneath the symbol shown above, this chemical symbol means that the battery or accumulator contains a heavy metal at a certain concentration. This will be indicated as follows:

Hg: mercury (0,0005%), Cd: cadmium (0,002%),

Pb: lead (0,004%)

In the European Union there are separate collection systems for used electrical and electronic products, batteries and accumulators.

Please, dispose of this equipment, batteries and accumulators correctly at your local community waste collection/recycling centre.

Please, help us to conserve the environment we live in!

Deutsch

Ihr MITSUBISHI ELECTRIC-Produkt wurde unter Einsatz von qualitativ hochwertigen Materialien und Komponenten konstruiert und gefertigt, die für Recycling und/oder Wiederverwendung geeignet sind.

Dieses Symbol bedeutet, dass elektrische und elektronische Geräte sowie Batterien und Akkus am Ende ihrer Nutzungsdauer von Hausmüll getrennt zu entsorgen sind.

Wenn ein chemisches Symbol unterhalb des oben abgebildeten Symbols erscheint, bedeutet dies, dass die Batterie bzw. der Akku ein Schwermetall in einer bestimmten Konzentration enthält. Dies wird wie folgt angegeben:

Hg: Quecksilber (0,0005%), Cd: Cadmium (0,002%),

Pb: Blei (0,004%)

In der Europäischen Union gibt es unterschiedliche Sammelsysteme für gebrauchte Elektrik- und Elektronikgeräte einerseits sowie Batterien und Akkus andererseits.

Bitte entsorgen Sie dieses Gerät, Batterien und Akkus vorschriftsmäßig bei Ihrer kommunalen Sammelstelle oder im örtlichen Recycling-Zentrum.

Bitte helfen Sie uns, die Umwelt zu erhalten, in der wir leben!

Italiano

Questo prodotto MITSUBISHI ELECTRIC è stato progettato e fabbricato con materiali e componenti di alta qualità, che possono essere riciclati e/o riutilizzati.

Questo simbolo significa che i prodotti elettrici ed elettronici, le batterie e gli accumulatori, devono essere smaltiti separatamente dai rifiuti casalinghi alla fine della loro vita di servizio.

Se sotto il simbolo mostrato sopra è stampato un simbolo chimico, il simbolo chimico significa che la batteria o l'accumulatore contiene un metallo pesante con una certa concentrazione. Ciò viene indicato come segue:

Hg: mercurio (0,0005%), Cd: cadmio (0,002%),

Pb: piombo (0,004%)

Nell'Unione Europea ci sono sistemi di raccolta differenziata per i prodotti elettrici ed elettronici, le batterie e gli accumulatori usati.

Per disfarsi di questo prodotto, delle batterie e degli accumulatori, portarli al centro locale di raccolta/riciclaggio dei rifiuti.

Aiutateci a conservare l'ambiente in cui viviamo!

Français

Votre produit Mitsubishi Electric est conçu et fabriqué avec des matériels et des composants de qualité supérieure qui peuvent être recyclés et/ou réutilisés.

Ce symbole signifie que les équipements électriques et électroniques, les batteries et les accumulateurs, à la fin de leur durée de service, doivent être éliminés séparément des ordures ménagères.

Si un symbole chimique est imprimé sous le symbole illustré ci-dessus, il signifie que la batterie ou l'accumulateur contient une certaine concentration de métal lourd. Elle sera indiquée comme suit :

Hg : mercure (0,0005%), Cd : cadmium (0,002%),

Pb : plomb (0,004%)

Dans l'Union Européenne, il existe des systèmes sélectifs de collecte pour les produits électriques et électroniques, les batteries et les accumulateurs usagés.

Nous vous prions donc de confier cet équipement, ces batteries et ces accumulateurs à votre centre local de collecte/recyclage.

Aidez-nous à conserver l'environnement dans lequel nous vivons !

Les machines ou appareils électriques et électroniques contiennent souvent des matières qui, si elles sont traitées ou éliminées de manière inappropriée, peuvent s'avérer potentiellement dangereuses pour la santé humaine et pour l'environnement.

Cependant, ces matières sont nécessaires au bon fonctionnement de votre appareil ou de votre machine.

Pour cette raison, il vous est demandé de ne pas vous débarrasser de votre appareil ou machine usagé avec vos ordures ménagères.

Español

Su producto MITSUBISHI ELECTRIC está diseñado y fabricado con materiales y componentes de alta calidad que pueden ser reciclados y/o reutilizados.

Este símbolo significa que el aparato eléctrico y electrónico, las pilas, baterías y los acumuladores, al final de su ciclo de vida, se deben tirar separadamente del resto de sus residuos domésticos.

Si hay un símbolo químico impreso debajo del símbolo mostrado arriba, este símbolo químico significa que la pila, batería o el acumulador contienen un metal pesado con cierta concentración. Esto se indicará de la forma siguiente:

Hg: mercurio (0,0005%), Cd: cadmio (0,002%),

Pb: plomo (0,004%)

En la Unión Europea existen sistemas de recogida específicos para productos eléctricos y electrónicos, pilas, baterías y acumuladores usados.

Por favor, deposite los aparatos mencionados, las pilas, baterías y acumuladores en el centro de recogida/reciclado de residuos de su lugar de residencia local cuando quiera tirarlos.

¡Ayúdenos a conservar el medio ambiente!

Português

O seu produto MITSUBISHI ELECTRIC foi concebido e produzido com materiais e componentes de alta qualidade que podem ser reciclados e/ou reutilizados.

Este símbolo significa que o equipamento eléctrico e electrónico, as baterias e os acumuladores, no final da sua vida útil, devem ser deitados fora separadamente do lixo doméstico.

Se houver um símbolo químico impresso por baixo do símbolo mostrado acima, o símbolo químico indica que a bateria ou acumulador contém metais pesados numa determinada concentração. Isto aparecerá indicado da maneira seguinte:

Hg: mercúrio (0,0005%), Cd: cádmio (0,002%),

Pb: chumbo (0,004%)

Na União Europeia existem sistemas de recolha separados para produtos eléctricos e electrónicos, baterias e acumuladores usados.

Por favor, entregue este equipamento, as baterias e os acumuladores correctamente, no seu ponto local de recolha/reciclagem.

Por favor, ajude-nos a conservar o ambiente em que vivemos!



Svenska

Denna produkt från MITSUBISHI ELECTRIC är designad och tillverkad av material och komponenter med hög kvalitet som kan återvinnas och/eller återanvändas.

Denna symbol betyder att förbrukade elektriska och elektroniska produkter, batterier och ackumulatörer skall sorteras och hanteras separat från hushållsavfall.

Om det finns en kemisk beteckning tryckt under ovanstående symbol betyder det att batteriet eller ackumulatören innehåller en tungmetall med en viss koncentration. Detta anges på följande sätt:

Hg: kvicksilver (0,0005%), Cd: kadmium (0,002%),
Pb: bly (0,004%)

Inom den Europeiska Unionen finns det separata insamlingsystem för begagnade elektriska och elektroniska produkter, batterier och ackumulatörer.

Var vänlig lämna denna produkt, batterier och ackumulatörer hos din lokala mottagningsstation för avfall och återvinning.

Var snäll och hjälp oss att bevara miljön vi lever i!

Dansk

Dit produkt fra MITSUBISHI ELECTRIC er designet og fremstillet med kvalitetsmaterialer og komponenter, der kan genindvindes og/eller genbruges.

Dette symbol viser, at elektrisk eller elektronisk udstyr, batterier og akkumulatører ikke må bortskaffes sammen med almindeligt husholdningsaffald efter endt levetid.

Hvis der er trykt et kemisk symbol under symbolet ovenfor, betyder det, at batteriet eller akkumulatøren indeholder en bestemt koncentration af et tungmetal. Dette angives som følger:

Hg: kviksølv (0,0005 %), Cd: cadmium (0,002 %),
Pb: bly (0,004 %)

I EU er der særlige indsamlingsordninger for brugte elektriske og elektroniske produkter, batterier og akkumulatører.

Bortskaf udstyret, batterier og akkumulatører korrekt på en lokal affalds-/genbrugsplads.

Hjælp os med at bevare det miljø, vi lever i!

Norsk

For norske brukere:

Dette produktet fra MITSUBISHI ELECTRIC er konstruert og produsert med materialer og komponenter av høy kvalitet, som kan resirkuleres og/eller brukes om igjen.

Dette symbolet betyr at elektrisk og elektronisk utstyr, batterier og akkumulatører, ikke bør kasseres sammen med husholdningsavfallet når de har nådd slutten av sin levetid.

Hvis det er trykt et kjemisk symbol under det symbolet som er vist over, betyr det kjemiske symbolet at batteriet eller akkumulatøren inneholder et tungmetall i en viss konsentrasjon. Dette vil vises som følger:

Hg: kvikksølv (0,0005 %), Cd: kadmium (0,002 %),
Pb: bly (0,004 %)

I Norge finnes det egne innsamlingsystemer for brukte elektriske og elektroniske produkter, batterier og akkumulatører. Kasser dette utstyret, batteriene og akkumulatørene ved den lokale gjenbruks- eller resirkuleringsstasjonen.

Hjelp oss å bevare det miljøet vi lever i!

Suomi

Tämä MITSUBISHI ELECTRIC -tuote on suunniteltu ja valmistettu korkealuokkaisista materiaaleista ja/tai osista, jotka voidaan kierrättää ja käyttää uudelleen.

Tämä symboli tarkoittaa, että sähkö- ja elektroniikkalaitteet, paristot ja akut täytyy niiden käyttöään jälkeen hävittää erillään talousjätteistä.

Jos yllä olevan symbolin alapuolelle on painettu kemiallinen symboli, se tarkoittaa, että paristolla tai akulla on tietty raskasmetallipitoisuus. Se ilmoitetaan seuraavasti:

Hg: elohopea (0,0005 %), Cd: kadmium (0,002 %),
Pb: lyijy (0,004 %)

Käytetyillä sähkö- ja elektroniikkalaitteilla, paristoilla ja akuilla on Euroopan Yhteisössä omat keräysjärjestelmänsä.

Toimita tämä laite, paristot ja akut paikalliseen jätehuolto-/kierrätyskeskukseen.

Auta meitä suojelemaan ympäristöä, jossa elämme!

Nederlands

Mitsubishi Electric producten zijn ontwikkeld en gefabriceerd uit eerste kwaliteit materialen. De onderdelen kunnen worden gerecycled en/of worden hergebruikt.

Het symbool betekent dat de elektrische en elektronische onderdelen, batterijen en accu's op het einde van de gebruiksduur gescheiden van het huishoudelijk afval moeten worden ingezameld. Wanneer er onder het bovenstaande symbool een chemisch symbool staat gedrukt, betekent dit dat de batterij of accu zware metalen in een bepaalde concentratie bevat. Dit wordt als volgt aangeduid:

Hg: kwik (0,0005%), Cd: cadmium (0,002%),
Pb: lood (0,004%)

In de Europese Unie worden elektrische en elektronische producten, batterijen en accu's afzonderlijk ingezameld.

Breng deze apparatuur, batterijen en accu's dan naar het gemeentelijke afvalinzamelingspunt.

Help ons mee het milieu te beschermen!

Ελληνικά

Το προϊόν MITSUBISHI ELECTRIC που διαθέτετε είναι σχεδιασμένο και κατασκευασμένο από υλικά και εξαρτήματα υψηλής ποιότητας, τα οποία μπορούν να ανακυκλωθούν ή/και να χρησιμοποιηθούν ξανά.

Το σύμβολο αυτό σημαίνει ότι ο ηλεκτρικός και ηλεκτρονικός εξοπλισμός, οι μπαταρίες και οι συσσωρευτές, στο τέλος της διάρκειας ζωής τους, θα πρέπει να απορριφτούν ξεχωριστά από τα υπόλοιπα οικιακά απορρίμμά σας.

Αν έχει εκτυπωθεί ένα χημικό σύμβολο κάτω από το σύμβολο που απεικονίζεται ανωτέρω, αυτό το χημικό σύμβολο σημαίνει ότι η μπαταρία ή ο συσσωρευτής περιέχει ένα βαρύ μέταλλο σε ορισμένη συγκέντρωση. Αυτό θα υποδεικνύεται ως ακολούθως:

Hg: υδράργυρος (0,0005%), Cd: κάδμιο (0,002%),
Pb: μόλυβδος (0,004%)

Στην Ευρωπαϊκή Ένωση υπάρχουν ξεχωριστά συστήματα συλλογής για τα χρησιμοποιημένα ηλεκτρικά και ηλεκτρονικά προϊόντα, τις μπαταρίες και τους συσσωρευτές.

Παρακαλούμε διαθέστε αυτόν τον εξοπλισμό, τις μπαταρίες και τους συσσωρευτές στο τοπικό σας κοινοτικό κέντρο συλλογής/ανακύκλωσης απορριμμάτων.

Βοηθήστε μας να προστατεύσουμε το περιβάλλον στο οποίο ζούμε!



Polski

Niniejszy wyrób MITSUBISHI ELECTRIC został zaprojektowany i wykonany z wysokiej jakości materiałów i części, które można poddać recyklingowi i/lub ponownie wykorzystać.

Symbol ten oznacza, że po zakończeniu okresu eksploatacji urządzeń elektrycznych i elektronicznych, baterii oraz akumulatorów nie należy ich utylizować razem z odpadami gospodarczymi.

Symbol chemiczny poniżej przedstawionego powyżej znaku sygnalizuje obecność w baterii bądź akumulatorze pewnego stężenia metali ciężkich. Informacja o tym podawana jest w następujący sposób:

Hg: rtęć (0,0005%), Cd: kadm (0,002%),

Pb: ołów (0,004%)

W krajach Unii Europejskiej działają odrębne systemy odbioru zużytych urządzeń elektrycznych i elektronicznych, baterii oraz akumulatorów.

Wspomniany sprzęt, baterie i akumulatory należy przekazać do utylizacji w miejscowym punkcie odbioru/recyklingu odpadów komunalnych.

Pomóż nam chronić środowisko, w którym żyjemy!

Český

Tento produkt společnosti MITSUBISHI ELECTRIC byl zkonstruován a vyroben z vysoce kvalitních materiálů a komponentů, které mohou být recyklovány nebo opakovaně použity.

Tento symbol znamená, že elektrické a elektronické zařízení, baterie a akumulátory musí být po skončení životnosti likvidovány odděleně od běžného komunálního odpadu.

Pokud je pod výše zobrazeným symbolem vtištěna chemická značka, znamená to, že baterie nebo akumulátor obsahuje v určité koncentraci těžký kov. Indikace bude provedena následujícím způsobem:

Hg: rtuť (0,0005 %), Cd: kadmium (0,002 %),

Pb: olovo (0,004 %)

V Evropské unii existují dva samostatné systémy sběru použitých elektrických a elektronických výrobků, baterií a akumulátorů.

Toto zařízení, baterie a akumulátory zlikvidujte prostřednictvím vašeho místního střediska sběru/recyklace odpadů.

Pomozte nám prosím zachovat životní prostředí, ve kterém žijeme!

Slovenský

Váš výrobok MITSUBISHI ELECTRIC je navrhnutý a vyrobený s použitím vysokokvalitných materiálov a komponentov, ktoré je možné recyklovať a/alebo opätovne použiť.

Tento symbol znamená, že elektrické a elektronické zariadenia, batérie a akumulátory je potrebné po ukončení ich životnosti zlikvidovať oddelene od komunálneho odpadu.

Ak je pod symbolom znázorneným vyššie vytlačený chemický symbol, tento chemický symbol znamená, že batéria alebo akumulátor obsahuje určitú koncentráciu ťažkého kovu. Koncentrácia sa uvádza nasledujúcim spôsobom:

Hg: ortuť (0,0005 %), Cd: kadmium (0,002 %),

Pb: olovo (0,004 %)

V Európskej únii existujú zvláštne systémy na zber použitých elektrických a elektronických výrobkov, batérií a akumulátorov.

Takéto zariadenia, batérie a akumulátory zlikvidujte správne v miestnom komunálnom centre zberu a recyklácie odpadu.

Pomôžte nám, prosím, zachovať prostredie, v ktorom žijeme!

Slovenščina

Izdelek MITSUBISHI ELECTRIC je načrtovan in izdelan iz materialov visoke kakovosti ter komponent, ki jih je mogoče reciklirati in/ali znova uporabiti.

Znak opozarja na to, da je treba električno in elektronsko opremo, baterije in akumulatorje, ki se jim je iztekla življenjska doba, ločiti od drugih gospodinjskih odpadkov, kadar jih želite zavreči.

Če je kemijski znak natisnjen pod zgoraj prikazanim znakom, kemijski znak pomeni, da je v bateriji ali akumulatorju določena koncentracija težke kovine. To je označeno tako:

Hg: živo srebro (0,0005 %), Cd: kadmij (0,002 %),

Pb: svinec (0,004 %)

Evropska unija je pripravila posebne skupne sisteme zbiranja uporabljenih električnih in elektronskih izdelkov, baterij in akumulatorjev.

Poskrbite za pravilno odlaganje takšne opreme, baterij in akumulatorjev v centru za zbiranje/recikliranje odpadkov lokalne skupnosti.

Pomagajte nam ohraniti naše okolje.

български

Продуктът на MITSUBISHI ELECTRIC е създаден и произведен с висококачествени материали и компоненти, които могат да бъдат рециклирани и/или повторно използвани.

Този символ означава, че електрическото или електронно оборудване, батерии или акумулатори в края на експлоатацията си живот трябва да бъдат изхвърляни отделно от останалите домакински отпадъци.

Ако под показания по-горе символ бъде отпечатан символ за химикал, означава че батерията или акумулатора съдържа тежък метал в определена концентрация. Това се указва както следва:

Hg: живак (0,0005%), Cd: кадмий (0,002%),

Pb: олово (0,004%)

В Европейския съюз има отделни системи за събиране на използвани електрически и електронни продукти, батерии и акумулатори.

Моля, изхвърляйте това оборудване, батерии и акумулатори, правилно в центъра за събиране/рециклиране на вашата община.

Помогнете да запазим средата, в която живеем!

Română

Produsul dvs. MITSUBISHI ELECTRIC este conceput și fabricat din materiale și componente de înaltă calitate, care pot fi reciclate și / sau reutilizate.

Acest simbol arată că, la sfârșitul duratei de viață, echipamentele electrice și electronice, bateriile și acumulatorii trebuie aruncate separat de deșeurile menajere obișnuite.

Dacă sub simbolul de mai sus este imprimat un simbol chimic, acesta arată că bateria sau acumulatorul conține metale grele într-o anumită concentrație. Prezența metalelor grele va fi indicată după cum urmează:

Hg: mercur (0,0005%), Cd: cadmiu (0,002%),

Pb: plumb (0,004%)

În Uniunea Europeană există sisteme de colectare separată a produselor electrice și electronice uzate, a bateriilor epuizate și a acumulatorilor uzați.

Vă rugăm să aruncați acest echipament, bateriile și acumulatorii în maniera corectă, prin intermediul centrului local de colectare / reciclare a deșeurilor.

Contribuiți la protejarea mediului în care trăim!



Magyar

MITSUBISHI ELECTRIC termékének tervezéséhez és gyártásához kiváló minőségű anyagok és alkatrészek kerültek felhasználásra. Ezek az anyagok újrahasznosíthatók és/vagy újrafelhasználhatók.

A szimbólum arra figyelmeztet, hogy az elektromos és elektronikus berendezéseket, elemeket és akkumulátorokat élettartamuk végén a háztartási hulladéktól különválasztva kell ártalmatlanítani.

Amennyiben a fenti szimbólum után vegyjel áll, az elem vagy az akkumulátor bizonyos koncentrációban nehézfémeket tartalmaz. A jelölések jelentése a következő:

Hg: higany (0,0005%), Cd: kadmium (0,002%),
Pb: ólom (0,004%)

Az Európai Unióban külön gyűjtőrendszerek működnek a használt elektromos és elektronikai cikkek, elemek és akkumulátorok ártalmatlanítására.

Kérjük, hogy a berendezést, az elemeket és az akkumulátorokat megfelelő módon a helyi hulladékgyűjtő/feldolgozó központban ártalmatlanítsa.

Kérjük, segítsen környezetünk megóvásában!

Русский

Ваш продукт MITSUBISHI ELECTRIC спроектирован и создан с использованием высококачественных материалов и компонентов, которые могут быть переработаны и/или использованы повторно.

Данный символ означает, что электрическое и электронное оборудование, батареи и аккумуляторы в конце срока службы должны утилизироваться отдельно от бытовых отходов.

Если под указанным выше символом напечатан химический символ, это означает, что батарея или аккумулятор содержит тяжелые металлы в определенной концентрации. Обозначения:

Hg: ртуть (0,0005%), Cd: кадмий (0,002%),
Pb: свинец (0,004%)

В Европейском Союзе предусмотрены отдельные системы сбора для отработавшего электрического и электронного оборудования, батарей и аккумуляторов.

Утилизируйте данное оборудование, батареи и аккумуляторы должным образом в местном центре сбора/переработки отходов.

Помогите нам защитить нашу окружающую среду!

Türkçe

MITSUBISHI ELECTRIC ürününüz, geri dönüştürülebilir ve/veya yeniden kullanılabilir yüksek kaliteli malzeme ve parçalarla tasarlanmıştır ve üretilmiştir.

Bu sembol, elektrikli ve elektronik cihazlar ile pil ve akülerin kullanım ömürlerinin sonunda evsel atıklarınızdan ayrı olarak atılması gerektiği anlamına gelir.

Yukarıda gösterilen sembolün altında bir kimyasal sembol varsa, bu kimyasal sembol pilin ya da akünün belirli bir yoğunlukta ağır metal içerdiği anlamına gelir. Bu gösterim aşağıdaki gibi olacaktır:

Hg: cıva (%0,0005), Cd: kadmium (%0,002),
Pb: kurşun (%0,004)

Avrupa Birliği bünyesinde kullanılmış elektrikli ve elektronik ürünler, pil ve aküler için ayrı toplama sistemleri bulunmaktadır.

Lütfen bu cihazı, pilleri ve aküleri bulunduğunuz bölgedeki belediyenin atık toplama/geri dönüşüm merkezinde doğru bir şekilde imha edin.

Lütfen içinde yaşadığımız çevreyi korumamız konusunda bize yardımcı olun!

Hrvatski

Vaš MITSUBISHI ELECTRIC proizvod projektiran je i proizveden od visokokvalitetnih materijala i dijelova koje je moguće reciklirati i/ili oporabiti.

Ovaj simbol ukazuje kako je nakon radnog vijeka električnu i elektroničku opremu, baterije i akumulatorne potrebno odlagati odvojeno od kućnog otpada.

Ako je ispod gore navedenog simbola tiskan kemijski simbol, on ukazuje kako baterija ili akumulator sadrži određenu koncentraciju teških metala. To će biti prikazano na primjer:

Hg: živa (0,0005%), Cd: kadmij (0,002%),
Pb: olovo (0,004%)

U Europskoj Uniji postoje zasebni sustavi prikupljanja iskorištenih električnih i elektroničkih proizvoda, baterija i akumulatora.

Ovu opremu, baterije i akumulatorne pravilno odložite u odgovarajućem lokalnom centru za prikupljanje i recikliranje otpada.

Pomozite nam u čuvanju okoliša u kojem živimo!

Lietuvių

Jūsų MITSUBISHI ELECTRIC gaminys suprojektuotas ir pagamintas naudojant aukštos kokybės medžiagas ir komponentus, kuriuos galima perdirbti ir (arba) naudoti pakartotinai.

Šis simbolis rodo, kad baigta naudoti elektrinė ir elektroninė įranga, baterijos ir akumuliatoriai turi būti šalinami ne su namų ūkio atliekomis.

Jei cheminis simbolis išspausdintas po prieš tai parodytu simboliu, jis nurodo, kad baterijoje arba akumuliatoriuje yra tam tikra koncentracija sunkiojo metalo. Tai gali būti nurodyta taip:

Hg: gyvsidabris (0,0005 %), Cd: kadmis (0,002 %),
Pb: švinas (0,004 %)

Europos Sąjungoje naudoti elektros ir elektroniniai gaminiai, baterijos ir akumuliatoriai šalinami atskiruose surinkimo punktuose.

Šią įrangą, baterijas ir akumuliatorius šalinkite tinkamai vietinės bendruomenės atliekų surinkimo / perdirbimo centre.

Padėkite mums saugoti aplinką, kurioje gyvename!

Latviski

Šis „MITSUBISHI ELECTRIC” iekārtas ražošanā izmantoti kvalitatīvi materiāli un detaļas, ko var pārstrādāt un/vai izmantot atkārtoti.

Šis simbols nozīmē, ka no elektriskajiem un elektroniskajiem komponentiem, baterijām un akumulatoriem to darbību beigās nedrīkst atbrīvoties kā no parastiem mājsaimniecības atkritumiem.

Ja zem iepriekš redzamā simbola ir norādīts ķīmiskā elementa simbols, tas nozīmē, ka baterijā vai akumulatorā noteiktā koncentrācijā ir smagais metāls. Koncentrācija tiek norādīta šādi:

Hg: dzīvsudrabs (0,0005%), Cd: kadmījs (0,002%),
Pb: svins (0,004%)

Eiropas Savienībā ir atsevišķas atkritumu savākšanas sistēmas elektriskajiem un elektriskajiem izstrādājumiem un izlietotām baterijām un akumulatoriem.

Atbrīvojieties no šīs iekārtas, baterijas un akumulatora pareizi, nododot tos vietējā atkritumu savākšanas/pārstrādes centrā.

Palīdziet saudzēt apkārtni, kurā mēs visi dzīvojam!



Eesti

Ettevõtte MITSUBISHI ELECTRIC seade on kavandatud ja valmistatud kvaliteetsetest materjalidest ning osadest, mida on võimalik ringlusse võtta ja/või taaskasutada.

See sümbol tähendab, et elektri- ja elektroonikaseadmed, patareid ja akud tuleb kõrvaldada pärast kasutusaja lõppu olmejäätmetest eraldi.

Kui ülaltoodud sümboli all on trükitud keemiline sümbol, siis see tähendab, et patarei või aku sisaldab teatud kontsentratsioonis raskemetalli. See märgitakse järgmiselt:

Hg: elavhõbe (0,0005%), Cd: kaadmium (0,002%),

Pb: plii (0,004%)

Euroopa Liidus kasutatakse kasutatud elektri- ja elektroonikaseadmete, patareide ning akude eraldi kogumise süsteeme.

Kõrvaldage see seade, patareid ja akud õigesti, viies need kohaliku jäätmekogumis- või ringlussevõtukeskusesse.

Aidake meil hoida keskkonda, kus me elame!

Українська мова

Ваш продукт MITSUBISHI ELECTRIC розроблено та виготовлено з високоякісних матеріалів та компонентів, які можна переробити та/або повторно використати.

Цей символ означає, що електричне й електронне обладнання, батареї та акумулятори після закінчення строку служби потрібно утилізувати окремо від побутових відходів.

Якщо хімічний символ надруковано під символом, показаним вище, цей хімічний символ означає, що батарея або акумулятор містить важкий метал у певній концентрації. Це буде позначено таким чином:

Hg: ртуть (0,0005%), Cd: кадмій (0,002%),

Pb: свинець (0,004%)

У Євросоюзі існують окремі системи збирання для використаних електричних та електронних виробів, батарей й акумуляторів.

Правильно утилізуйте це обладнання, батареї та акумулятори у своєму місцевому центрі збирання/переробки відходів.

Будь ласка, допоможіть нам зберегти природне довкілля, у якому живемо!